

Page Thumbnails X

Thumbnail navigation pane with icons for Home, Copy, Paste, Undo, Redo, and a vertical scrollbar. The first thumbnail is highlighted with a blue border and labeled '66'.

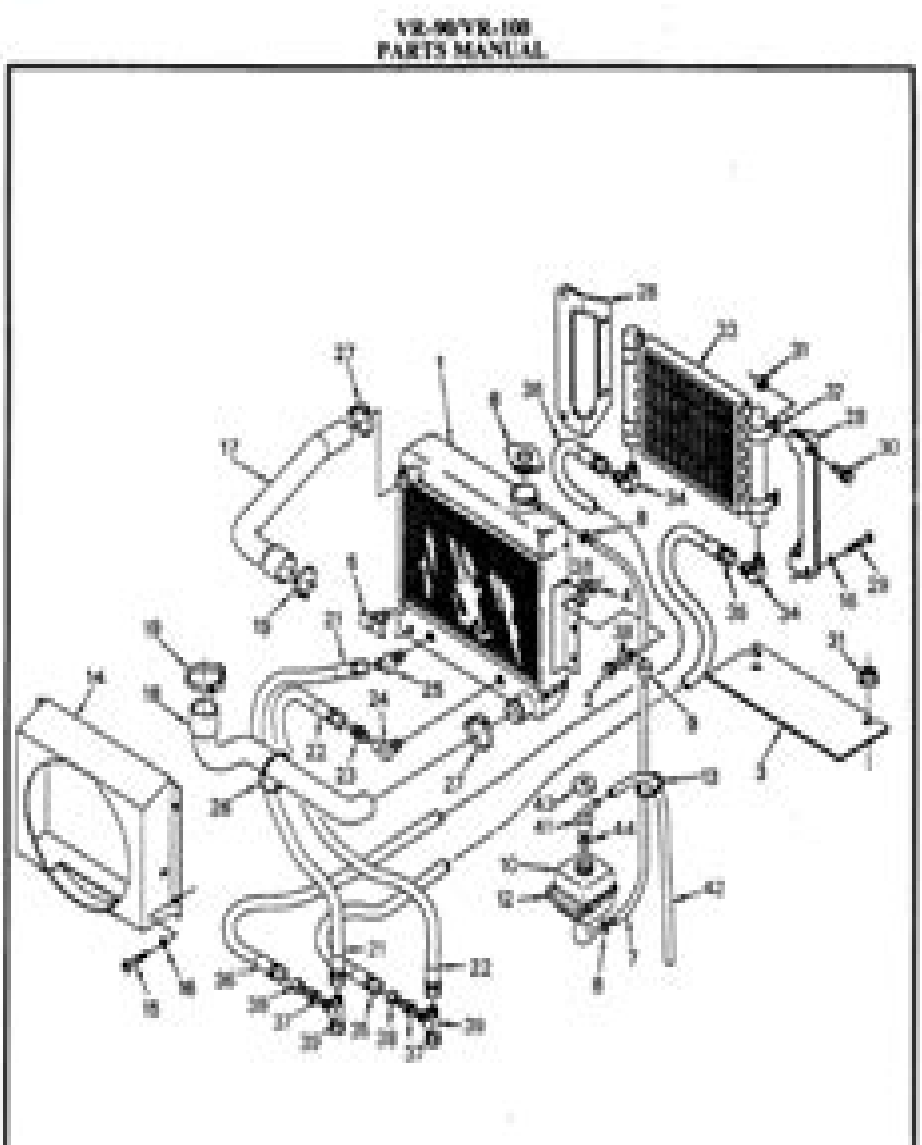

# Vr90 Ingersoll Parts Manual

**Chilton Book Company**



**Vr90 Ingersoll Parts Manual:**

*Parts Manual Var Man HPU-HCL* ,2006      *Import Labor Guide and Parts Manual, 1991-95* Nichols Publishing Company,1995-06-01      *Chilton's 1985 Import Labor Guide and Parts Manual* ,1985      Chilton's 1996 Import Labor Guide and Parts Manual Kerry A. Freeman,Chilton Book Company,1996      **Chilton's 1990 Labor and Parts Manual** Chilton Book Company,1988

This is likewise one of the factors by obtaining the soft documents of this **Vr90 Ingersoll Parts Manual** by online. You might not require more times to spend to go to the books commencement as competently as search for them. In some cases, you likewise accomplish not discover the pronouncement Vr90 Ingersoll Parts Manual that you are looking for. It will unquestionably squander the time.

However below, in the same way as you visit this web page, it will be hence utterly simple to acquire as with ease as download lead Vr90 Ingersoll Parts Manual

It will not consent many period as we tell before. You can attain it while feint something else at house and even in your workplace. consequently easy! So, are you question? Just exercise just what we have enough money under as competently as review **Vr90 Ingersoll Parts Manual** what you like to read!

<https://ftp.barnabastoday.com/results/publication/fetch.php/World%20Atlas%20Of%20Seagrasses.pdf>

## **Table of Contents Vr90 Ingersoll Parts Manual**

1. Understanding the eBook Vr90 Ingersoll Parts Manual
  - The Rise of Digital Reading Vr90 Ingersoll Parts Manual
  - Advantages of eBooks Over Traditional Books
2. Identifying Vr90 Ingersoll Parts Manual
  - Exploring Different Genres
  - Considering Fiction vs. Non-Fiction
  - Determining Your Reading Goals
3. Choosing the Right eBook Platform
  - Popular eBook Platforms
  - Features to Look for in an Vr90 Ingersoll Parts Manual
  - User-Friendly Interface
4. Exploring eBook Recommendations from Vr90 Ingersoll Parts Manual

- Personalized Recommendations
  - Vr90 Ingersoll Parts Manual User Reviews and Ratings
  - Vr90 Ingersoll Parts Manual and Bestseller Lists
5. Accessing Vr90 Ingersoll Parts Manual Free and Paid eBooks
    - Vr90 Ingersoll Parts Manual Public Domain eBooks
    - Vr90 Ingersoll Parts Manual eBook Subscription Services
    - Vr90 Ingersoll Parts Manual Budget-Friendly Options
  6. Navigating Vr90 Ingersoll Parts Manual eBook Formats
    - ePub, PDF, MOBI, and More
    - Vr90 Ingersoll Parts Manual Compatibility with Devices
    - Vr90 Ingersoll Parts Manual Enhanced eBook Features
  7. Enhancing Your Reading Experience
    - Adjustable Fonts and Text Sizes of Vr90 Ingersoll Parts Manual
    - Highlighting and Note-Taking Vr90 Ingersoll Parts Manual
    - Interactive Elements Vr90 Ingersoll Parts Manual
  8. Staying Engaged with Vr90 Ingersoll Parts Manual
    - Joining Online Reading Communities
    - Participating in Virtual Book Clubs
    - Following Authors and Publishers Vr90 Ingersoll Parts Manual
  9. Balancing eBooks and Physical Books Vr90 Ingersoll Parts Manual
    - Benefits of a Digital Library
    - Creating a Diverse Reading Collection Vr90 Ingersoll Parts Manual
  10. Overcoming Reading Challenges
    - Dealing with Digital Eye Strain
    - Minimizing Distractions
    - Managing Screen Time
  11. Cultivating a Reading Routine Vr90 Ingersoll Parts Manual
    - Setting Reading Goals Vr90 Ingersoll Parts Manual
    - Carving Out Dedicated Reading Time
  12. Sourcing Reliable Information of Vr90 Ingersoll Parts Manual

- Fact-Checking eBook Content of Vr90 Ingersoll Parts Manual
  - Distinguishing Credible Sources
13. Promoting Lifelong Learning
- Utilizing eBooks for Skill Development
  - Exploring Educational eBooks
14. Embracing eBook Trends
- Integration of Multimedia Elements
  - Interactive and Gamified eBooks

### **Vr90 Ingersoll Parts Manual Introduction**

In the digital age, access to information has become easier than ever before. The ability to download Vr90 Ingersoll Parts Manual has revolutionized the way we consume written content. Whether you are a student looking for course material, an avid reader searching for your next favorite book, or a professional seeking research papers, the option to download Vr90 Ingersoll Parts Manual has opened up a world of possibilities. Downloading Vr90 Ingersoll Parts Manual provides numerous advantages over physical copies of books and documents. Firstly, it is incredibly convenient. Gone are the days of carrying around heavy textbooks or bulky folders filled with papers. With the click of a button, you can gain immediate access to valuable resources on any device. This convenience allows for efficient studying, researching, and reading on the go. Moreover, the cost-effective nature of downloading Vr90 Ingersoll Parts Manual has democratized knowledge. Traditional books and academic journals can be expensive, making it difficult for individuals with limited financial resources to access information. By offering free PDF downloads, publishers and authors are enabling a wider audience to benefit from their work. This inclusivity promotes equal opportunities for learning and personal growth. There are numerous websites and platforms where individuals can download Vr90 Ingersoll Parts Manual. These websites range from academic databases offering research papers and journals to online libraries with an expansive collection of books from various genres. Many authors and publishers also upload their work to specific websites, granting readers access to their content without any charge. These platforms not only provide access to existing literature but also serve as an excellent platform for undiscovered authors to share their work with the world. However, it is essential to be cautious while downloading Vr90 Ingersoll Parts Manual. Some websites may offer pirated or illegally obtained copies of copyrighted material. Engaging in such activities not only violates copyright laws but also undermines the efforts of authors, publishers, and researchers. To ensure ethical downloading, it is advisable to utilize reputable websites that prioritize the legal distribution of content. When downloading Vr90 Ingersoll Parts Manual, users should also consider the potential security risks associated with online

platforms. Malicious actors may exploit vulnerabilities in unprotected websites to distribute malware or steal personal information. To protect themselves, individuals should ensure their devices have reliable antivirus software installed and validate the legitimacy of the websites they are downloading from. In conclusion, the ability to download Vr90 Ingersoll Parts Manual has transformed the way we access information. With the convenience, cost-effectiveness, and accessibility it offers, free PDF downloads have become a popular choice for students, researchers, and book lovers worldwide. However, it is crucial to engage in ethical downloading practices and prioritize personal security when utilizing online platforms. By doing so, individuals can make the most of the vast array of free PDF resources available and embark on a journey of continuous learning and intellectual growth.

### FAQs About Vr90 Ingersoll Parts Manual Books

1. Where can I buy Vr90 Ingersoll Parts Manual books? Bookstores: Physical bookstores like Barnes & Noble, Waterstones, and independent local stores. Online Retailers: Amazon, Book Depository, and various online bookstores offer a wide range of books in physical and digital formats.
2. What are the different book formats available? Hardcover: Sturdy and durable, usually more expensive. Paperback: Cheaper, lighter, and more portable than hardcovers. E-books: Digital books available for e-readers like Kindle or software like Apple Books, Kindle, and Google Play Books.
3. How do I choose a Vr90 Ingersoll Parts Manual book to read? Genres: Consider the genre you enjoy (fiction, non-fiction, mystery, sci-fi, etc.). Recommendations: Ask friends, join book clubs, or explore online reviews and recommendations. Author: If you like a particular author, you might enjoy more of their work.
4. How do I take care of Vr90 Ingersoll Parts Manual books? Storage: Keep them away from direct sunlight and in a dry environment. Handling: Avoid folding pages, use bookmarks, and handle them with clean hands. Cleaning: Gently dust the covers and pages occasionally.
5. Can I borrow books without buying them? Public Libraries: Local libraries offer a wide range of books for borrowing. Book Swaps: Community book exchanges or online platforms where people exchange books.
6. How can I track my reading progress or manage my book collection? Book Tracking Apps: Goodreads, LibraryThing, and Book Catalogue are popular apps for tracking your reading progress and managing book collections. Spreadsheets: You can create your own spreadsheet to track books read, ratings, and other details.
7. What are Vr90 Ingersoll Parts Manual audiobooks, and where can I find them? Audiobooks: Audio recordings of books,

- perfect for listening while commuting or multitasking. Platforms: Audible, LibriVox, and Google Play Books offer a wide selection of audiobooks.
8. How do I support authors or the book industry? Buy Books: Purchase books from authors or independent bookstores. Reviews: Leave reviews on platforms like Goodreads or Amazon. Promotion: Share your favorite books on social media or recommend them to friends.
  9. Are there book clubs or reading communities I can join? Local Clubs: Check for local book clubs in libraries or community centers. Online Communities: Platforms like Goodreads have virtual book clubs and discussion groups.
  10. Can I read Vr90 Ingersoll Parts Manual books for free? Public Domain Books: Many classic books are available for free as they're in the public domain. Free E-books: Some websites offer free e-books legally, like Project Gutenberg or Open Library.

### **Find Vr90 Ingersoll Parts Manual :**

*world atlas of seagrasses*

[world upside down reading acts in the graeco roman age](#)

~~workshop manual for iseki 3cylinder diesel engine~~

~~write a western in 30 days with plenty of bullet points~~

*worlds in our words contemporary american women writers*

*wright group mcgraw hill everyday mathematics answers*

**workshop manual kia carnival 2005**

[world of reading thor this is thor level 1](#)

*world literature metamorphosis study guide questions answers*

[workshop manual fiat tractor 1880 dt](#)

[world history series the fall of vietnam](#)

**workshop manual volvo penta s drive stern**

[world history final exam multiple choice matching](#)

[workshop statistics discovery with data and the graphing calculator](#)

**wow hunter rare pet guide**



**Vr90 Ingersoll Parts Manual :**

[pdf 13 case studies in human resource management and management](#) - Aug 13 2023

web oct 19 2022 the case studies from many fields from the human resource management social science and management perspective explore the academics experience

*human resource management applications cases exercises incidents* - Oct 15 2023

web oct 10 2007 hrm applications is an interesting and useful book particularly for lecturers and tutors the interesting and topical cases incidents exercises and skill builders are excellent the step by step and integrative approach of this book sets itself apart from most contemporary hrm textbook resource materials

**1 4 cases and problems human resource management** - Sep 14 2023

web human resource management involves seven main areas 1 staffing 2 workplace policies 3 benefits and compensation 4 retention 5 training 6 employment laws and 7 employee protection

**human resource management case study with solutions** - May 30 2022

web aug 8 2023 chapter exploring dependence of human resource management hrm on internet of things iot and digital mark june 2023 shafaq zareen shad ahmad khan the field of human resource

*cases in human resource management sage publications inc* - May 10 2023

web description contents resources reviews features preview cases in human resource management provides students with insights into common challenges dilemmas and issues human resource managers face in the workplace

[human resource management the ultimate guide capterra](#) - Aug 01 2022

web nov 10 2023 human resource management is the practice of recruiting hiring deploying and managing a team of employees however successful hr managers do more than manage people they set them up with essential tools and resources hrm involves the creation of policies and procedures that support business objectives it is a

[a review of machine learning applications in human resource management](#) - Jul 12 2023

web feb 2 2021 7927 abstract purpose this paper reviews 105 scopus indexed articles to identify the degree scope and purposes of machine learning ml adoption in the core functions of human resource management hrm design methodology approach a semi systematic approach has been used in this review

[applications in human resource management cases exercises](#) - Nov 04 2022

web programmes human resource management case studies jun 04 2020 cases in public human resource management mar 14 2021 this collection of actual case studies with only names changed is appropriate for both graduates and undergraduates taking courses in public personnel management human resources management or employment

**human resource management applications cases exercises** - Oct 03 2022

web sep 29 2010 an emphasis on problem solving and decision making throughout the exercises make human resource management applications 7e ideal for any level of study new and updated cases and applications drawn from actual current events highlight a variety of organizations and industries including today s growing service sector

*work employment and human resource management case study applications* - Mar 08 2023

web pdf on feb 28 2020 tony dundon and others published work employment and human resource management case study applications find read and cite all the research you need on researchgate

applications in human resource management cases exercises - Feb 07 2023

web applications in human resource management cases exercises skill builders s nkomo m fottler r mcafee published 1996 business a model for analyzing cases in personnel human resource management part 1 introduction to personnel human resource management part 2 the legal and regulatory environment of

*human resource management applications cases exercises incidents* - Jun 30 2022

web the digital and etextbook isbn for human resource management applications cases exercises incidents and skill builders are 9781133170471 1133170471 and the print isbn are 9781133459057 1133459056 save up to 80 versus print by going digital with vitalsource additional isbn for this etextbook include 9781111548025

human resource management applications cases exercises - Jan 06 2023

web human resource management applications cases exercises incidents and skill builders 7th edition 9780538468077

cengage supplement your introductory human resource management course with this unique single source for the latest cases exercises incidents and skill builders including a comprehensive term project and

**human resource management applications cases exercises** - Apr 09 2023

web apr 17 2007 human resource management applications cases exercises incidents and skill builders stella nkomo myron d fottler r bruce mcafee cengage learning apr 17 2007 business economics

pdf applications in human resource management a study of - Dec 05 2022

web sep 30 2021 pdf for the purpose of achieving four research objectives 1 to describe general meaning types and utility of applications in human resource find read and cite all the research you

human resource management applications cases exercises - Feb 24 2022

web sep 29 2010 human resource management applications cases exercises and skill builders 7e focuses on the abilities most important in hrm today with timely new cases and applications drawn from a variety of real organizations including those in today s growing service sector

**human resource management applications cases exercises incidents** - Jun 11 2023

web sep 29 2010 human resource management applications cases exercises and skill builders 7e focuses on the abilities

most important in hrm today with timely new cases and applications drawn from a variety of real organizations including those in today s growing service sector

**human resource management practices a case study of** - Apr 28 2022

web jan 1 2014 human resource management practices a case study of south asia n countries vol 9 no 1 spring 2014 91 the absence of suitable hr competence the ongoing arrangement is not likely to work for a

best pdf human resource management applications cases - Mar 28 2022

web jun 25 2020 best pdf human resource management applications cases exercises incidents and skill builders 7th edition full pdf online pdf download human resource management applications cases exercises incidents and skill builders 7th edition read human resource management applications cases exercises

human resource applications 2023 effective applications of hris - Sep 02 2022

web oct 23 2023 human resource applications centralize all this information and the tasks surrounding them accessing and tracking information becomes much more manageable with everything stored in a single database and with a self service portal added to the mix employees can easily find and update their info 4

**teaching to kill a mockingbird facing history and ourselves** - Feb 26 2022

web mar 14 2016 for educators who choose to teach to kill a mockingbird or whose districts mandate it we offer this collection of classroom ready activities documentary style videos primary source readings and more

to kill a mockingbird film study guide gradesaver - Mar 30 2022

web to kill a mockingbird film study guide contains a biography of robert mulligan literature essays quiz questions major themes characters and a full summary and analysis best summary pdf themes and quotes

*to kill a mockingbird study guide sparknotes* - Aug 15 2023

web to kill a mockingbird is harper lee s 1961 pulitzer prize winning novel about a child s view of race and justice in the depression era south the book sells one million copies per year and scout remains one of the most beloved characters in american fiction explore a character analysis of scout the plot summary and important quotes summary

**to kill a mockingbird film study guide media literacy clearinghouse** - Oct 05 2022

web voted 25 afi s 100 years 100 movies 19 of the 101 greatest screenplays actors gregory peck left atticus finch and brock peters right tom robinson in a publicity still from the 1962 film to kill a mockingbird

**to kill a mockingbird unit plan grade 8 to grade 10** - Jan 28 2022

web reading 1 building character reading 2 the true boo reading 3 1930s america reading 4 atticus v maycomb reading 5 tkm and the scottsboro affair reading 6 it s complicated structure final exam and project beyond the mockingbird symbolism reading schedules to print to kill a mockingbird lessons pre reading lessons

**to kill a mockingbird by harper lee summer reading unit overview** - Jan 08 2023

web novel structure to kill a mockingbird is divided into two parts part i deals with the children s attempt to get boo radley the neighborhood recluse to come out

[to kill a mockingbird study guide chino valley unified school](#) - Apr 11 2023

web din context published in 1960 harper lee s to kill a mockingbird was an immediate success winning the pulitzer prize for fiction in 1961 the novel was turned into a popular motion picture in 1962 at the academy awards actor gregory peck won an oscar for his portrayal of atticus finch

**to kill a mockingbird study guide packet** - Nov 06 2022

web to kill a mockingbird study guide packet is genial in our digital library an online right of entry to it is set as public in view of that you can download it instantly our digital library saves in combined countries allowing you to get the most less latency era to download

**revision pack to kill a mockingbird ks4 english teachit** - Sep 04 2022

web feb 21 2023 resource type student activity revision title to kill a mockingbird author harper lee questions for each chapter of to kill a mockingbird exploring characters plot setting and language there are essay style questions at the end of the resource to consolidate students knowledge

[literature grade 12 national department of basic education](#) - Aug 03 2022

web poetry a mind the gap study guide is available for each of the prescribed literature titles choose the study guide for the set works you studied in your efal class at school this study guide focuses on harper lee s novel to kill a mockingbird one of the set works in paper 2 literature how to use this study guide

*to kill a mockingbird lesson plans enotes com* - Apr 30 2022

web to kill a mockingbird trial study guide by katemschultz the ewells v tom robinson lawyer for the ewells lawyer for tom robinson name of the judge where is the trial taking place building

**to kill a mockingbird film 1962 study guide movie packet tpt** - Jul 02 2022

web description the following twelve page study guide film packet is used to accompany the robert mulligan directed 1962 courtroom drama to kill a mockingbird that is an adaptation of harper lee s novel of the same name and stars gregory peck it can be used in an english or film studies classroom

[to kill a mockingbird study guide course hero](#) - Dec 07 2022

web this study guide and infographic for harper lee s to kill a mockingbird offer summary and analysis on themes symbols and other literary devices found in the text explore course hero s library of literature materials including documents and q a pairs

**to kill a mockingbird novel units student packet grades 9 12** - Jun 01 2022

web easy to understand and a wonderful tool for improving students comprehension and analysis of literature this student study guide contains study questions vocabulary and comprehension activities projects essays quizzes and tests

*a teacher s guide to harpercollins* - May 12 2023

web harper lee s to kill a mockingbird meets the standard for range of reading and level of text complexity for middle and high school grades since the novel is most commonly taught in middle school this guide is aligned to the common core standards for grade 8 it is easily adaptable to a variety of grade levels and classes ccss ela literacy rl 8 10

**to kill a mockingbird by harper lee study guide** - Feb 09 2023

web includes bibliographical references page 48 this teaching guide includes focusing on the background of the novel elements of the novel vocabulary from the novel plot synopsis and literary focus reading guide questions testing on

**to kill a mockingbird stacey lloyd packet flashcards and study** - Dec 27 2021

web learn to kill a mockingbird stacey lloyd packet with free interactive flashcards choose from 90 different sets of to kill a mockingbird stacey lloyd packet flashcards on quizlet

to kill a mockingbird study guide gradesaver - Jun 13 2023

web the to kill a mockingbird study guide contains a biography of harper lee literature essays quiz questions major themes characters and a f best summary pdf themes and quotes more books than sparknotes

**to kill a mockingbird study guide literature guide litcharts** - Jul 14 2023

web the best study guide to to kill a mockingbird on the planet from the creators of sparknotes get the summaries analysis and quotes you need

**teaching mockingbird facing history ourselves** - Mar 10 2023

web may 10 2022 this guide includes student handouts close reading exercises and connection questions that will push students to build a complex understanding of the historical realities social dynamics and big moral questions at the heart of to kill a mockingbird following facing history s scope and sequence students will consider the

wechat for asha 210 banpaen - Oct 29 2022

web jun 4 2023 you could buy manual wechat for asha 210 or get it as soon as feasible you would not require more time frame to expend to go to the ebook launch as skillfully as search for them merely said the wechat for asha 210 is commonly consistent with any devices to read banpaen com 1 4

**wechat for asha 210 book help environment harvard edu** - Aug 07 2023

web wechat for asha 210 the concise encyclopædia of living faiths apr 07 2022 the zend avesta oct 01 2021 this is a subset of the sacred books of the east series which includes translations of all the most important works of the seven non christian

religions which have exercised a profound influence on the civilizations of the continent of asia

[get the free download aplikasi wechat nokia asha 210 pdfiller](#) - Apr 03 2023

web get the free download aplikasi wechat nokia asha 210 get form show details hide details home hsbc com uk coupon code for babies r us 20 off one item for end of june upon code for babies r us 20 off one it frees netflix accounts and passwords 10 free netflix accounts and passwords 10 jonathan

**wechat for asha 210 mail thekingiscoming com** - Jul 26 2022

web 4 wechat for asha 210 2022 06 23 legislative seats in the world women s movements lobbied for constitutional reforms and new legislation to expand women s rights this book examines the convergence of factors behind these dramatic developments including the emergence of autonomous women s movements changes in international and regional

[wechat available for nokia asha review and how to download](#) - Oct 09 2023

web feb 26 2017 wechat the cross platform messaging app was recently launched for asha full touch phones a less advanced version was previously available only for keypad based nokia x3 02 c3 01 the new redesigned application also brings the ability to record and send short voice messages from within the application

**wechat for asha 210 waptac org** - Sep 08 2023

web wechat for asha 210 wechat for asha 210 2 downloaded from waptac org on 2019 09 06 by guest geopolitically complex region edited by respected scholars in the field the collection comprises five new research contributions by established and early career researchers who have been significantly engaged in the himalayan region

[wechat for asha 210 rhur impacthub net](#) - May 04 2023

web title wechat for asha 210 author rhur impacthub net 2023 08 27 23 31 58 subject wechat for asha 210 keywords wechat for asha 210 created date

**wechat for asha 2055 rhur impacthub net** - Aug 27 2022

web wechat for asha 2055 download aplikasi bbm nokia asha 302 dojemohu gg db 7 52 pembaruan perangkat lunak dan download nokia download new whatsapp for nokia c3 free mobile apps mobile9 nokia asha 210 specs phone arena nokia asha 210 full phone specifications gsm arena wechat c2 pdf excido de download aplikasi alkitab

**wechat for asha 210 helpdesk bricksave com** - Jun 05 2023

web 2 2 wechat for asha 210 2022 07 12 handbook of large scale distributed computing in smart healthcare cambridge university press emergency radiology requires consistent timely and accurate imaging interpretation with the

**wechat for asha 210 speakings gestamp** - Jun 24 2022

web wechat for asha 210 you could buy handbook wechat for asha 210 or get it as soon as achievable still when realize you give a affirmative reply that you call for to get those every necessities in the likewise as having considerably currency access

the wechat for asha 210 join that we have the money for here and check out the link

**wechatforasha210 mcarnoy book** - Dec 31 2022

web 2 wechat for asha 210 and x2 01 is not great microsoft community yesterday i have downloaded we chat my nokia x2 01 and on my sister phone asha 210 and there are huge

*wechat for asha 210 smis school co tz* - May 24 2022

web wechat for asha 210 1 omb no wechat for asha 210 original nokia asha 210 worldstarthink nokia announces bright and budget friendly asha 210 nokia asha 210 hands on engadget nokia asha 210 commercial nokia asha 210 charging 2 variants new nokia feature phone with 5gwifi hotspot whatsapp youtube supportnokia

*wechat for asha 210 uniport edu ng* - Feb 01 2023

web may 14 2023 wechat for asha 210 2 11 downloaded from uniport edu ng on may 14 2023 by guest foundation for care of the patient during the vulnerable period immediately following cardiac surgery a comprehensive resource this text serves as a foundation for nurses beginning to care for cardiac surgery patients as well

**a clayton kershaw dodgers split would be understandable los** - Feb 18 2022

web 20 hours ago unimaginable but understandable clayton kershaw pitching against the san francisco giants on sept 23 had his left shoulder operated on last month it was the first surgery of his career gina

**wechat for asha 210 phone cholaca com** - Mar 02 2023

web 2 wechat for asha 210 2021 08 13 user experience and usability duxu 2020 held as part of the 22nd international conference on human computer interaction hcii 2020 in copenhagen denmark in july 2020 the conference was held virtually due to the covid 19 pandemic from a total of 6326 submissions a total of 1439 papers and 238 posters

**asher property on instagram 98 wireless available for** - Mar 22 2022

web 15 likes 2 comments asher property on may 12 2020 98 wireless available for sale and rent starting price 70 million ba

**wechat for asha 210 help environment harvard edu** - Apr 22 2022

web wechat for asha 210 if you ally habit such a referred wechat for asha 210 books that will have enough money you worth get the completely best seller from us currently from several preferred authors if you want to witty books lots of novels tale jokes and more fictions collections are with launched from best

*wechat for asha 210 dns1 bcca* - Sep 27 2022

web indulge in the present is wechat for asha 210 below in the trajectory of them is this wechat for asha 210 that can be your collaborator we settle for you this correct as expertly as straightforward airs to fetch those all wechat for asha 210 is obtainable in our novel assemblage an online access to it is

**wechat for asha 210 uniport edu ng** - Nov 29 2022

web apr 15 2023 wechat for asha 210 is available in our book collection an online access to it is set as public so you can get it instantly our digital library saves in multiple countries allowing you to get the most less latency time to download any

**wechat for asha 210 pdf blueskywildlife** - Jul 06 2023

web sep 15 2023 tiny grow old to gain access to this on line publication wechat for asha 210 pdf as without difficulty as review them wherever you are now neuroepigenomics in aging and disease raul delgado morales 2017 05 18