

MAIN COMPONENTS

4/5

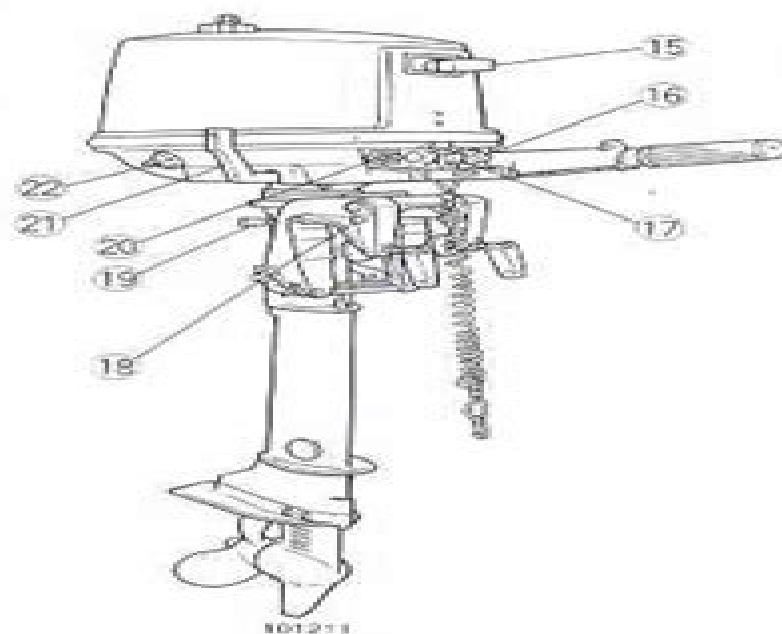
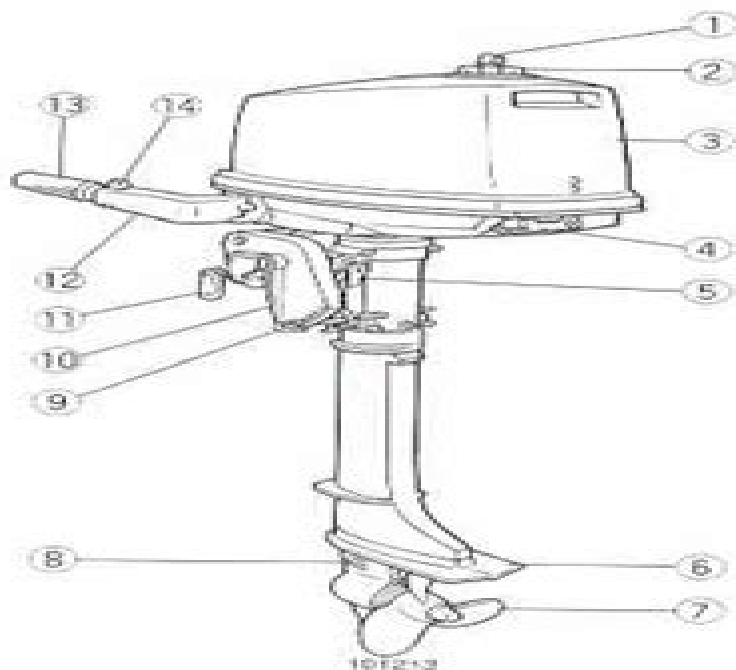

- ① Air vent screw
- ② Fuel tank cap
- ③ Top cowling
- ④ Cowling lock lever
- ⑤ Steering friction adjusting lever
- ⑥ Anti-cavitation plate
- ⑦ Propeller
- ⑧ Cooling water inlet
- ⑨ Trim angle adjusting-rod
- ⑩ Clamp bracket
- ⑪ Transom clamp handle

- ⑫ Tiller handle
- ⑬ Throttle control grip
- ⑭ Throttle friction adjusting knob
- ⑮ Recoil starter handle
- ⑯ Choke knob
- ⑰ Engine stop button/
Engine stop lanyard switch
- ⑱ Rope attachment
- ⑲ Tilt support lever
- ⑳ Fuel connector
- ㉑ Gear shift lever
- ㉒ Fuel cock lever

Yamaha Outboard 2b Manual

Chao Zhang



Yamaha Outboard 2b Manual:

Yamaha Outboard Shop Manual Kalton C. Lahue,1986 **Popular Mechanics** ,1968-10 Popular Mechanics inspires instructs and influences readers to help them master the modern world Whether it s practical DIY home improvement tips gadgets and digital technology information on the newest cars or the latest breakthroughs in science PM is the ultimate guide to our high tech lifestyle **AC Maintenance & Repair Manual for Outboard Motors** Jean Luc Pallas,2013-08-10 The aim of this book with its detailed step by step colour photographs and diagrams is to enable every owner to fix their outboard motor with ease Troubleshooting tables help diagnose potential problems and there is advice on regular maintenance and winterising and repair Jean Luc Pallas s enthusiasm for passing on his knowledge as well as his clear explanations precise advice and step by step instructions make this a unique book **Outboard Motor Service Manual** Intertec Publishing,1987 Detailed tips on periodic servicing troubleshooting general maintenance and repair are explicitly outlined in this manual Repair is easy with the specifications and step by step repair procedures included for hundreds of models Volume II covers models with 30hp and above *Books in Print Supplement* ,2002 **Small Engines Service Manual** Intertec Publishing Corporation,1985-10 Popular Mechanics ,1974-03 Popular Mechanics inspires instructs and influences readers to help them master the modern world Whether it s practical DIY home improvement tips gadgets and digital technology information on the newest cars or the latest breakthroughs in science PM is the ultimate guide to our high tech lifestyle *Popular Mechanics* ,1968-10 Popular Mechanics inspires instructs and influences readers to help them master the modern world Whether it s practical DIY home improvement tips gadgets and digital technology information on the newest cars or the latest breakthroughs in science PM is the ultimate guide to our high tech lifestyle *Subject Guide to Books in Print* ,1993 *Bibliography of Nautical Books* ,1998 **Bicycle** ,1985 Explains specific procedures for maintaining and repairing bicycles and includes detailed diagrams of parts **The Fisherman's Electrical Manual** John C. Payne,2003 This handbook presents the bewildering array of electrical and electronic devices found aboard modern trailerable fishing boats With Payne s help every bass and sports fisherman should be able to make the right choices for his boat s equipment *Yachting* ,1995-06 Popular Mechanics ,1969-11 Popular Mechanics inspires instructs and influences readers to help them master the modern world Whether it s practical DIY home improvement tips gadgets and digital technology information on the newest cars or the latest breakthroughs in science PM is the ultimate guide to our high tech lifestyle **Popular Mechanics** ,1970 **Boating** ,1998-01 Cruising World ,1986-01 **Fuels and Lubricants Handbook** , *Field & Stream* ,1987-04 FIELD STREAM America s largest outdoor sports magazine celebrates the outdoor experience with great stories compelling photography and sound advice while honoring the traditions hunters and fishermen have passed down for generations *Paperbound Books in Print* ,1991

This is likewise one of the factors by obtaining the soft documents of this **Yamaha Outboard 2b Manual** by online. You might not require more get older to spend to go to the book creation as without difficulty as search for them. In some cases, you likewise attain not discover the declaration Yamaha Outboard 2b Manual that you are looking for. It will no question squander the time.

However below, like you visit this web page, it will be appropriately entirely easy to get as capably as download guide Yamaha Outboard 2b Manual

It will not resign yourself to many epoch as we accustom before. You can pull off it even if perform something else at house and even in your workplace. in view of that easy! So, are you question? Just exercise just what we offer under as without difficulty as evaluation **Yamaha Outboard 2b Manual** what you next to read!

<https://ftp.barnabastoday.com/results/Resources/default.aspx/une%20semaine%20avec%20lui%20gratuit.pdf>

Table of Contents Yamaha Outboard 2b Manual

1. Understanding the eBook Yamaha Outboard 2b Manual
 - The Rise of Digital Reading Yamaha Outboard 2b Manual
 - Advantages of eBooks Over Traditional Books
2. Identifying Yamaha Outboard 2b Manual
 - Exploring Different Genres
 - Considering Fiction vs. Non-Fiction
 - Determining Your Reading Goals
3. Choosing the Right eBook Platform
 - Popular eBook Platforms
 - Features to Look for in an Yamaha Outboard 2b Manual
 - User-Friendly Interface
4. Exploring eBook Recommendations from Yamaha Outboard 2b Manual

- Personalized Recommendations
 - Yamaha Outboard 2b Manual User Reviews and Ratings
 - Yamaha Outboard 2b Manual and Bestseller Lists
5. Accessing Yamaha Outboard 2b Manual Free and Paid eBooks
 - Yamaha Outboard 2b Manual Public Domain eBooks
 - Yamaha Outboard 2b Manual eBook Subscription Services
 - Yamaha Outboard 2b Manual Budget-Friendly Options
 6. Navigating Yamaha Outboard 2b Manual eBook Formats
 - ePub, PDF, MOBI, and More
 - Yamaha Outboard 2b Manual Compatibility with Devices
 - Yamaha Outboard 2b Manual Enhanced eBook Features
 7. Enhancing Your Reading Experience
 - Adjustable Fonts and Text Sizes of Yamaha Outboard 2b Manual
 - Highlighting and Note-Taking Yamaha Outboard 2b Manual
 - Interactive Elements Yamaha Outboard 2b Manual
 8. Staying Engaged with Yamaha Outboard 2b Manual
 - Joining Online Reading Communities
 - Participating in Virtual Book Clubs
 - Following Authors and Publishers Yamaha Outboard 2b Manual
 9. Balancing eBooks and Physical Books Yamaha Outboard 2b Manual
 - Benefits of a Digital Library
 - Creating a Diverse Reading Collection Yamaha Outboard 2b Manual
 10. Overcoming Reading Challenges
 - Dealing with Digital Eye Strain
 - Minimizing Distractions
 - Managing Screen Time
 11. Cultivating a Reading Routine Yamaha Outboard 2b Manual
 - Setting Reading Goals Yamaha Outboard 2b Manual
 - Carving Out Dedicated Reading Time
 12. Sourcing Reliable Information of Yamaha Outboard 2b Manual

- Fact-Checking eBook Content of Yamaha Outboard 2b Manual
 - Distinguishing Credible Sources
13. Promoting Lifelong Learning
- Utilizing eBooks for Skill Development
 - Exploring Educational eBooks
14. Embracing eBook Trends
- Integration of Multimedia Elements
 - Interactive and Gamified eBooks

Yamaha Outboard 2b Manual Introduction

Yamaha Outboard 2b Manual Offers over 60,000 free eBooks, including many classics that are in the public domain. Open Library: Provides access to over 1 million free eBooks, including classic literature and contemporary works. Yamaha Outboard 2b Manual Offers a vast collection of books, some of which are available for free as PDF downloads, particularly older books in the public domain. Yamaha Outboard 2b Manual : This website hosts a vast collection of scientific articles, books, and textbooks. While it operates in a legal gray area due to copyright issues, its a popular resource for finding various publications. Internet Archive for Yamaha Outboard 2b Manual : Has an extensive collection of digital content, including books, articles, videos, and more. It has a massive library of free downloadable books. Free-eBooks Yamaha Outboard 2b Manual Offers a diverse range of free eBooks across various genres. Yamaha Outboard 2b Manual Focuses mainly on educational books, textbooks, and business books. It offers free PDF downloads for educational purposes. Yamaha Outboard 2b Manual Provides a large selection of free eBooks in different genres, which are available for download in various formats, including PDF. Finding specific Yamaha Outboard 2b Manual, especially related to Yamaha Outboard 2b Manual, might be challenging as theyre often artistic creations rather than practical blueprints. However, you can explore the following steps to search for or create your own Online Searches: Look for websites, forums, or blogs dedicated to Yamaha Outboard 2b Manual, Sometimes enthusiasts share their designs or concepts in PDF format. Books and Magazines Some Yamaha Outboard 2b Manual books or magazines might include. Look for these in online stores or libraries. Remember that while Yamaha Outboard 2b Manual, sharing copyrighted material without permission is not legal. Always ensure youre either creating your own or obtaining them from legitimate sources that allow sharing and downloading. Library Check if your local library offers eBook lending services. Many libraries have digital catalogs where you can borrow Yamaha Outboard 2b Manual eBooks for free, including popular titles. Online Retailers: Websites like Amazon, Google Books, or Apple Books often sell eBooks. Sometimes, authors or publishers offer promotions or free periods for certain books. Authors Website

Occasionally, authors provide excerpts or short stories for free on their websites. While this might not be the Yamaha Outboard 2b Manual full book, it can give you a taste of the authors writing style. Subscription Services Platforms like Kindle Unlimited or Scribd offer subscription-based access to a wide range of Yamaha Outboard 2b Manual eBooks, including some popular titles.

FAQs About Yamaha Outboard 2b Manual Books

1. Where can I buy Yamaha Outboard 2b Manual books? Bookstores: Physical bookstores like Barnes & Noble, Waterstones, and independent local stores. Online Retailers: Amazon, Book Depository, and various online bookstores offer a wide range of books in physical and digital formats.
2. What are the different book formats available? Hardcover: Sturdy and durable, usually more expensive. Paperback: Cheaper, lighter, and more portable than hardcovers. E-books: Digital books available for e-readers like Kindle or software like Apple Books, Kindle, and Google Play Books.
3. How do I choose a Yamaha Outboard 2b Manual book to read? Genres: Consider the genre you enjoy (fiction, non-fiction, mystery, sci-fi, etc.). Recommendations: Ask friends, join book clubs, or explore online reviews and recommendations. Author: If you like a particular author, you might enjoy more of their work.
4. How do I take care of Yamaha Outboard 2b Manual books? Storage: Keep them away from direct sunlight and in a dry environment. Handling: Avoid folding pages, use bookmarks, and handle them with clean hands. Cleaning: Gently dust the covers and pages occasionally.
5. Can I borrow books without buying them? Public Libraries: Local libraries offer a wide range of books for borrowing. Book Swaps: Community book exchanges or online platforms where people exchange books.
6. How can I track my reading progress or manage my book collection? Book Tracking Apps: Goodreads, LibraryThing, and Book Catalogue are popular apps for tracking your reading progress and managing book collections. Spreadsheets: You can create your own spreadsheet to track books read, ratings, and other details.
7. What are Yamaha Outboard 2b Manual audiobooks, and where can I find them? Audiobooks: Audio recordings of books, perfect for listening while commuting or multitasking. Platforms: Audible, LibriVox, and Google Play Books offer a wide selection of audiobooks.
8. How do I support authors or the book industry? Buy Books: Purchase books from authors or independent bookstores. Reviews: Leave reviews on platforms like Goodreads or Amazon. Promotion: Share your favorite books on social media

- or recommend them to friends.
9. Are there book clubs or reading communities I can join? Local Clubs: Check for local book clubs in libraries or community centers. Online Communities: Platforms like Goodreads have virtual book clubs and discussion groups.
 10. Can I read Yamaha Outboard 2b Manual books for free? Public Domain Books: Many classic books are available for free as they're in the public domain. Free E-books: Some websites offer free e-books legally, like Project Gutenberg or Open Library.

Find Yamaha Outboard 2b Manual :

une semaine avec lui gratuit

unit 3 geometry and spatial sense answers

une si troublante attention

unended quest an intellectual autobiography author sir karl popper published on september 2002

~~unglaubliche kraft farben jean gabriel cause~~

understanding military doctrine a multidisciplinary approach cass military studies

unit 1 practice springboard

une seule eucharistie le pain unique

understanding perspective form depth and distance the art of drawing

~~uniform trust and estate statutes 2014-2015-selected statutes~~

unit 6 worksheet 2 finding coterminal angles

unit 5 achievement test pearson longman

~~understanding government finance~~

unfashionable observations volume 2 the complete works of friedrich nietzsche

unit 5 ap human geography study guide

Yamaha Outboard 2b Manual :

Pipe fitter NCCER Flashcards Study Flashcards On Pipe fitter NCCER at Cram.com. Quickly memorize the terms, phrases and much more. Cram.com makes it easy to get the grade you want! Pipefitter Nccer V4 study guide Flashcards Study with Quizlet and memorize flashcards containing terms like OSHA approved anchorage point, 3 1/2, 30 PSI and more. Free Pipefitter Practice Test with Questions and Answers 2023 This is a free Pipefitter practice test with full answers and

explanations, to give you a taste of the real exam. Pipefitter Test - Fill Online, Printable, Fillable, Blank | pdfFiller General pipefitter interview questions Tell us something about yourself. How did you know about this job opportunity? Do you know anyone already working for ... Pipefitting Pipefitting covers key concepts of installation and repair of high- and low-pressure pipe systems used in manufacturing, in the generation of electricity and ... pipe fitter test Flashcards Study with Quizlet and memorize flashcards containing terms like What does TE in TE-601 stand for?, what does B.T.U stand for?, what is the boiling point of ... nccer pipefitter test answers Discover videos related to nccer pipefitter test answers on TikTok. Nccer Pipefitting Level 2 Drawings And Detail Sheets Study Flashcards On Nccer pipefitting level 2 drawings and detail sheets at Cram.com. Quickly memorize the terms, phrases and much more. Chemistry Final Exam Review (Hanover Horton High School) Start studying Chemistry Final Exam Review (Hanover Horton High School). Learn vocabulary, terms, and more with flashcards, games, and other study tools. CHEMISTRY TEST REVIEW OVER MOLES UNIT Moles Practice Test At STP, which sample contains the same number of molecules as 11.2 liters of CO₂(g) at STP? Page 4. Answer Key moles practice test. 1. C. 2. C. 3. D. 4. C. 5. A. Nadeb videos 6 years ago. 1:25. Nadeb. Mole Test Review Answer Key Horton High School. 6 years ago. 1:25. Nadeb. How To Replace Drive Belt On Yamaha Stratoliner. 6 years ago. Stoichiometry Review Sheets 2.pdf X moles = 399. 26. LIFE 7+ 19. Page 7. Name: Answer Key. 1. Base your answer to ... Determine the total number of moles of CO₂ produced during the lantern test. Relative Mass and the Mole answer key Use a periodic table to answer the following questions. a. Fluorine gas consists of diatomic molecules of fluorine (F). How many molecules of fluorine are in ... Conceptual Chemistry MOLES & EMPIRICAL FORMULA ... May 5, 2020 — Conceptual Chemistry MOLES & EMPIRICAL FORMULA Test Review 1. A mole is equal to : representative particles grams liters (for gases only) 2. Msrazz chem class the mole answer key ... mole answer key Balancing combustion Chemistry test review answers - earthstaff. ... High School chemistry is one of the most high-yield areas for study. pogil ... Gif Dr Doe is here to test your knowledge of chemistry! Answer correctly, she strips. Made using the Topaz Gigapixel AI 5. Stay on topic, be respectful, no low ... Earth Science, Teacher's Edition: Edward J. Tarbuck ... Earth Science Workbook. PRENTICE HALL. 4.1 out of 5 stars 32. Paperback. 23 offers ... Prentice Hall Earth Science. Edward J. Tarbuck. Prentice Hall: Earth Science - TEACHER'S EDITION Book details ; Print length. 804 pages ; Language. English ; Publisher. Pearson Prentice Hall ; Publication date. January 1, 2006 ; ISBN-10. 0131905643. Prentice Hall Earth Science: Guided Reading and Study ... Prentice Hall Earth Science: Guided Reading and Study Workbook, Level A, Teacher's Edition. by Pearson Education. No reviews. Choose a condition: About our ... earth science teachers edition prentice hall Exploring Earth Science: Teacher's Edition: Prentice Hall by Johnson Hopkins and a great selection of related books, art and collectibles available now at ... Prentice Hall Earth Science for sale Prentice Hall Earth Science Guided Reading and Study Workbook Student Edition... Pre-Owned. Prentice Hall Earth Science: Guided Reading and Study ... Prentice Hall Earth Science: Guided Reading and Study Workbook, Level A, Teacher's Edition by Education, Pearson - ISBN 10: 0133627624 -

ISBN 13: ... Prentice Hall Earth Science: Guided Reading and Study ... 2007 Prentice Hall Earth Science -- [Differentiated Instruction / Tools for All Learners] Guided Reading and Study Workbook Teacher's Edition (TE)(P) ***Key ... Prentice Hall Earth Science: Guided Reading and Study ... Prentice Hall Earth Science: Guided Reading and Study Workbook, Level A, Teacher's Edition 0133627624 9780133627626 - New. USD\$65.94. Prentice Hall Earth Science: Guided Reading and Study ... Prentice Hall Earth Science: Guided Reading and Study Workbook, Level A, Teacher's Edition by Pearson Education isbn: 0133627624. isbn13: 9780133627626. Prentice Hall Earth Science: Guided Reading and Study ... Prentice Hall Earth Science: Guided Reading and Study Workbook, Level A, Teacher's Edition ; ISBN-13: 9780133627626 ; ISBN-10: 0133627624 ; Publication date: 2007.