

6. EXPLODED VIEW

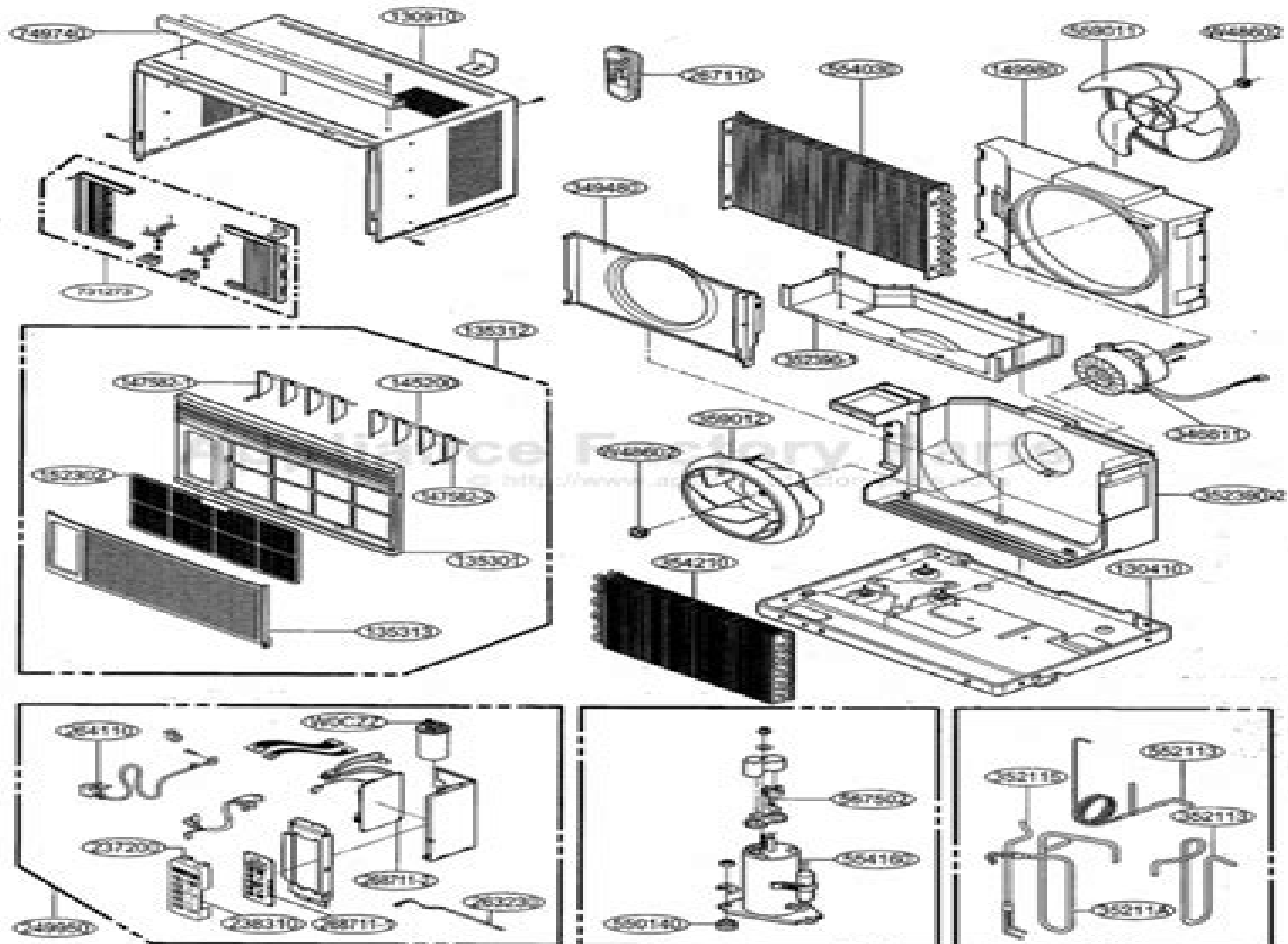

Zenith Zw6510r Manual

Zenith Data Systems (Firm)



Zenith Zw6510r Manual:

Zenith Product Manual Hydrotap Company Ltd,2008 **Z-100 PC Series Service Manual** Zenith Data Systems (Firm),1984 **Z-100 Series Computers** Zenith Data Systems (Firm),1985 **Z-200 Series** Zenith Data Systems Corporation,1986 **Z386SX16/20** Zenith Data Systems (Firm). Groupe Bull,1990 ZCM-1492 Zenith Data Systems (Firm),1989 *Z-150 PC Series Computers* Zenith Data Systems (Firm),1986 **Z-140 PC Series Computers** Zenith Data Systems (Firm),1895

When people should go to the book stores, search foundation by shop, shelf by shelf, it is in reality problematic. This is why we provide the books compilations in this website. It will entirely ease you to look guide **Zenith Zw6510r Manual** as you such as.

By searching the title, publisher, or authors of guide you in point of fact want, you can discover them rapidly. In the house, workplace, or perhaps in your method can be every best area within net connections. If you take aim to download and install the Zenith Zw6510r Manual, it is unconditionally easy then, in the past currently we extend the connect to purchase and create bargains to download and install Zenith Zw6510r Manual appropriately simple!

<https://ftp.barnabastoday.com/About/book-search/index.jsp/yamaha%2030%20hp%20outboard%20repair%20manual.pdf>

Table of Contents Zenith Zw6510r Manual

1. Understanding the eBook Zenith Zw6510r Manual
 - The Rise of Digital Reading Zenith Zw6510r Manual
 - Advantages of eBooks Over Traditional Books
2. Identifying Zenith Zw6510r Manual
 - Exploring Different Genres
 - Considering Fiction vs. Non-Fiction
 - Determining Your Reading Goals
3. Choosing the Right eBook Platform
 - Popular eBook Platforms
 - Features to Look for in an Zenith Zw6510r Manual
 - User-Friendly Interface
4. Exploring eBook Recommendations from Zenith Zw6510r Manual
 - Personalized Recommendations
 - Zenith Zw6510r Manual User Reviews and Ratings
 - Zenith Zw6510r Manual and Bestseller Lists

5. Accessing Zenith Zw6510r Manual Free and Paid eBooks
 - Zenith Zw6510r Manual Public Domain eBooks
 - Zenith Zw6510r Manual eBook Subscription Services
 - Zenith Zw6510r Manual Budget-Friendly Options
6. Navigating Zenith Zw6510r Manual eBook Formats
 - ePub, PDF, MOBI, and More
 - Zenith Zw6510r Manual Compatibility with Devices
 - Zenith Zw6510r Manual Enhanced eBook Features
7. Enhancing Your Reading Experience
 - Adjustable Fonts and Text Sizes of Zenith Zw6510r Manual
 - Highlighting and Note-Taking Zenith Zw6510r Manual
 - Interactive Elements Zenith Zw6510r Manual
8. Staying Engaged with Zenith Zw6510r Manual
 - Joining Online Reading Communities
 - Participating in Virtual Book Clubs
 - Following Authors and Publishers Zenith Zw6510r Manual
9. Balancing eBooks and Physical Books Zenith Zw6510r Manual
 - Benefits of a Digital Library
 - Creating a Diverse Reading Collection Zenith Zw6510r Manual
10. Overcoming Reading Challenges
 - Dealing with Digital Eye Strain
 - Minimizing Distractions
 - Managing Screen Time
11. Cultivating a Reading Routine Zenith Zw6510r Manual
 - Setting Reading Goals Zenith Zw6510r Manual
 - Carving Out Dedicated Reading Time
12. Sourcing Reliable Information of Zenith Zw6510r Manual
 - Fact-Checking eBook Content of Zenith Zw6510r Manual
 - Distinguishing Credible Sources
13. Promoting Lifelong Learning

- Utilizing eBooks for Skill Development
 - Exploring Educational eBooks
14. Embracing eBook Trends
- Integration of Multimedia Elements
 - Interactive and Gamified eBooks

Zenith Zw6510r Manual Introduction

In today's digital age, the availability of Zenith Zw6510r Manual books and manuals for download has revolutionized the way we access information. Gone are the days of physically flipping through pages and carrying heavy textbooks or manuals. With just a few clicks, we can now access a wealth of knowledge from the comfort of our own homes or on the go. This article will explore the advantages of Zenith Zw6510r Manual books and manuals for download, along with some popular platforms that offer these resources. One of the significant advantages of Zenith Zw6510r Manual books and manuals for download is the cost-saving aspect. Traditional books and manuals can be costly, especially if you need to purchase several of them for educational or professional purposes. By accessing Zenith Zw6510r Manual versions, you eliminate the need to spend money on physical copies. This not only saves you money but also reduces the environmental impact associated with book production and transportation. Furthermore, Zenith Zw6510r Manual books and manuals for download are incredibly convenient. With just a computer or smartphone and an internet connection, you can access a vast library of resources on any subject imaginable. Whether you're a student looking for textbooks, a professional seeking industry-specific manuals, or someone interested in self-improvement, these digital resources provide an efficient and accessible means of acquiring knowledge. Moreover, PDF books and manuals offer a range of benefits compared to other digital formats. PDF files are designed to retain their formatting regardless of the device used to open them. This ensures that the content appears exactly as intended by the author, with no loss of formatting or missing graphics. Additionally, PDF files can be easily annotated, bookmarked, and searched for specific terms, making them highly practical for studying or referencing. When it comes to accessing Zenith Zw6510r Manual books and manuals, several platforms offer an extensive collection of resources. One such platform is Project Gutenberg, a nonprofit organization that provides over 60,000 free eBooks. These books are primarily in the public domain, meaning they can be freely distributed and downloaded. Project Gutenberg offers a wide range of classic literature, making it an excellent resource for literature enthusiasts. Another popular platform for Zenith Zw6510r Manual books and manuals is Open Library. Open Library is an initiative of the Internet Archive, a non-profit organization dedicated to digitizing cultural artifacts and making them accessible to the public. Open Library hosts millions of books, including both public domain works and contemporary titles. It also allows users to borrow digital copies of certain books for a limited

period, similar to a library lending system. Additionally, many universities and educational institutions have their own digital libraries that provide free access to PDF books and manuals. These libraries often offer academic texts, research papers, and technical manuals, making them invaluable resources for students and researchers. Some notable examples include MIT OpenCourseWare, which offers free access to course materials from the Massachusetts Institute of Technology, and the Digital Public Library of America, which provides a vast collection of digitized books and historical documents. In conclusion, Zenith Zw6510r Manual books and manuals for download have transformed the way we access information. They provide a cost-effective and convenient means of acquiring knowledge, offering the ability to access a vast library of resources at our fingertips. With platforms like Project Gutenberg, Open Library, and various digital libraries offered by educational institutions, we have access to an ever-expanding collection of books and manuals. Whether for educational, professional, or personal purposes, these digital resources serve as valuable tools for continuous learning and self-improvement. So why not take advantage of the vast world of Zenith Zw6510r Manual books and manuals for download and embark on your journey of knowledge?

FAQs About Zenith Zw6510r Manual Books

1. Where can I buy Zenith Zw6510r Manual books? Bookstores: Physical bookstores like Barnes & Noble, Waterstones, and independent local stores. Online Retailers: Amazon, Book Depository, and various online bookstores offer a wide range of books in physical and digital formats.
2. What are the different book formats available? Hardcover: Sturdy and durable, usually more expensive. Paperback: Cheaper, lighter, and more portable than hardcovers. E-books: Digital books available for e-readers like Kindle or software like Apple Books, Kindle, and Google Play Books.
3. How do I choose a Zenith Zw6510r Manual book to read? Genres: Consider the genre you enjoy (fiction, non-fiction, mystery, sci-fi, etc.). Recommendations: Ask friends, join book clubs, or explore online reviews and recommendations. Author: If you like a particular author, you might enjoy more of their work.
4. How do I take care of Zenith Zw6510r Manual books? Storage: Keep them away from direct sunlight and in a dry environment. Handling: Avoid folding pages, use bookmarks, and handle them with clean hands. Cleaning: Gently dust the covers and pages occasionally.
5. Can I borrow books without buying them? Public Libraries: Local libraries offer a wide range of books for borrowing. Book Swaps: Community book exchanges or online platforms where people exchange books.

6. How can I track my reading progress or manage my book collection? Book Tracking Apps: Goodreads, LibraryThing, and Book Catalogue are popular apps for tracking your reading progress and managing book collections. Spreadsheets: You can create your own spreadsheet to track books read, ratings, and other details.
7. What are Zenith Zw6510r Manual audiobooks, and where can I find them? Audiobooks: Audio recordings of books, perfect for listening while commuting or multitasking. Platforms: Audible, LibriVox, and Google Play Books offer a wide selection of audiobooks.
8. How do I support authors or the book industry? Buy Books: Purchase books from authors or independent bookstores. Reviews: Leave reviews on platforms like Goodreads or Amazon. Promotion: Share your favorite books on social media or recommend them to friends.
9. Are there book clubs or reading communities I can join? Local Clubs: Check for local book clubs in libraries or community centers. Online Communities: Platforms like Goodreads have virtual book clubs and discussion groups.
10. Can I read Zenith Zw6510r Manual books for free? Public Domain Books: Many classic books are available for free as they're in the public domain. Free E-books: Some websites offer free e-books legally, like Project Gutenberg or Open Library.

Find Zenith Zw6510r Manual :

yamaha 30 hp outboard repair manual

yamaha 125 rd motorcycle owners manual

y se ahorrar y se ahorrar

[yamaha cy50 jog full service repair manual 1991 2000](#)

yamaha br250 bravo workshop service repair manual

~~yamaha 40 hp 2 stroke outboard for sale~~

[xr250 owners manual](#)

yamaha 650 service manual

~~xlh 883 deluxe owners manual~~

[yamaha 99 outboard motor owners manual](#)

yamaha 50hp four stroke manual

[y guides manual](#)

[yamaha av receiver manuals](#)

[yamaha aerox scooter manual](#)

[yale forklift manual for model glp 25](#)

Zenith Zw6510r Manual :

[examination guidelines accounting grade 11 paper - Jun 06 2022](#)

web accounting grade 11 examination guidelines with effect from january 2019 contents page 1 overview 3 2 format of an accounting year end examination paper 3 3 content for grade 11 accounting 5 4 relevant sections of caps for accounting which have a direct effect on the setting of examination papers 6 5 degrees of difficulty 6 6 appendix 1

grade 11 accounting past papers sa papers - Aug 08 2022

web accounting government grade 11 past papers access the largest collection of past exam papers for grade 11 caps prepare for your grade 11 exams our website offers a wide range of grade 11 past papers study guides and other study materials to help you excel in your studies and achieve academic success

[class 11 accountancy sample papers with answers pdf - Nov 11 2022](#)

web sep 14 2023 class 11 accountancy sample paper 1 download pdf class 11 accountancy sample paper 2 download pdf class 11 accountancy sample paper 3 download pdf class 11 accountancy sample paper 4 download pdf class 11 accountancy sample paper 5 download pdf

[grade 11 november 2020 accounting p2 exemplar - Jun 18 2023](#)

web grade 11 november 2020 accounting p2 exemplar marks 150 time 2 hours this question paper consists of 11 pages a 1 page formula sheet and a 9 page answer book

accounting grade 11 exam papers and memos 2020 2019 and - Mar 15 2023

web download accounting grade 11 exam papers and memos 2020 accounting grade 11 past papers and memos for 2020 download accounting grade 11 exam papers and memos 2019 accounting grade 11 past papers and memos for 2019 download accounting grade 11 exam papers and memos 2018

class 11 account model question pdf 2080 the sr zone - Mar 03 2022

web account is a very important subject for all 11th graders because it deals with basic accounting rules this helps you learn the basics better if you study it right business transaction analysis bank reconciliation statement trial balance error correction depreciation and provision will be explained in this subject

grade 11 accounting exam papers testpapers - Sep 21 2023

web past exam papers for grade 11 accounting 2023 2012 past march june september and november exam papers memos available in afrikaans and english download all question papers for free

gr11 case study term 3 2022 qp accounting grade 11 - Apr 04 2022

web accounting grade 11 school based assesment term 3 case study question paper question topic marks allocated suggested time one periodic inventory 20 20 minutes two cash budget 40

provincial assessment north west - Apr 16 2023

web provincial assessment grade 11 accounting paper 1 june 2019 marks 150 time 2 hours this question paper consists of 10 pages and 01 formula sheet instructions and information read the following instructions carefully and follow them precisely answer all questions a special answer book is provided in which to

grade 11 accounting november exam and memo paper 2 2023 - Jul 07 2022

web oct 17 2023 han wep grade 11 accounting november exam paper 1 and memo total 150 marks 120 minutes contents question 1 fixed assets and internal control 32 marks question 2 reconciliations 36 marks question 3 cash budgets 25 marks question 4 inventory systems and vat 23 marks question 5 cost accounting 34

gr 11 accounting p1 english november 2022 question paper - Oct 10 2022

web gr 11 accounting p1 english november 2022 question paper business studies school lane technical high school chicago il degree standard subject accounting 315 documents students shared 315 documents in this course academic year 2021 2022 comments please sign in or register to post comments recommended for you 21

accounting exam papers and study notes for grade 11 - Sep 09 2022

web sep 14 2023 exam papers and study notes for accounting grade 11 download free question papers and memos study notes are available as well

2019 grade 11 exemplars national department of basic education - Dec 12 2022

web 2019 grade 11 exemplars accounting title p1 gr 11 exemplar nov 2019 afr download p1 gr 11 exemplar nov 2019 answer book afr grade 12 past exam papers ana exemplars matric results curriculum curriculum assessment policy statements practical assessment tasks school based assessment

national senior certificate grade 11 national - Jan 13 2023

web sep 11 2019 9 use the information in the table below as a guide when answering the question paper try not to deviate from it question 1 40 marks 30 minutes topic of the question this question integrates vat and reconciliation concepts and calculations creditors reconciliation internal control question 2 45 marks 40 minutes

[accounting grade 11 exam papers and memos 2023 pdf download](#) - Jul 19 2023

web may 15 2023 download grade 11 accounting papers and memorandum pdf accounting grade 11 exam papers and memos for 2023 can be downloaded below these papers and memos are essential for any grade 11 accounting student as they provide valuable practice for the upcoming exams

national senior certificate grade 11 national - May 17 2023

web sep 11 2019 grade 11 marks 150 time 2 hours this question paper consists of 11 pages a 1 page formula sheet and a 9 page answer book turn over nsc grade 11 exemplar instructions and information read the following instructions carefully and follow them precisely answer all the questions

study master accounting cambridge university press - May 05 2022

web grade 11 teacher s guide sm accounting 11 tg tp caps eng indd 1 2012 08 07 3 00 pm c a m b r i d g e university p r e s s cambridge new york melbourne madrid cape town the assessment matrix for both the exam paper and the marking memorandum should be included with each section

cbse class 11 accountancy previous year question papers - Feb 02 2022

web download question papers for class 11 accountancy for past years 10 year access solved question papers for class 11 accountancy for previous years issued by cbse and ncert download question papers with solutions in pdf free

accounting grade 11 exam papers and memos for revision - Aug 20 2023

web jul 8 2019 list of accounting grade 11 past papers and memos for 2020 paper 1 accounting p1 gr11 answer book november 2020 afrikaans docx download accounting p1 gr11 answer book november 2020 english docx download accounting p1 gr11 memo november 2020 afrikaans docx download

accounting grade 11 past papers and memos for 2021 - Feb 14 2023

web apr 16 2021 this page contains the latest accounting grade 11 past papers and memos for 2021 content on this page will help you in your exams tests sba assignments and research tasks accounting focuses on measuring performance and processing and communicating financial information about economic sectors this discipline ensures that

summer reading 10 grade links to short stories a p by pdf copy - Jun 16 2023

web jun 2 2023 summer reading 10 grade links to short stories a p by pdf is available in our digital library an online access to it is set as public so you can get it instantly our digital library hosts in multiple countries allowing you to get the most less latency time to download any of

pdf summer reading 10 grade links to short stories a p by - Aug 18 2023

web summer reading 10 grade links to short stories a p by a collection of short stories poems jul 12 2022 this is a book of short stories of everyday human emotional experiences stories of profound loss stories of great friendships stories of growing old with a dog of going to war and of course stories of deep romantic love

summer reading 10 grade links to short stories a p by pdf - Nov 09 2022

web you to acquire the most less latency epoch to download any of our books in the same way as this one merely said the summer reading 10 grade links to short stories a p by pdf is universally compatible subsequent to any devices to read the

boys in the boat daniel james brown 2021 03 30

summer reading 10 grade links to short stories a p by pdf pdf - Jun 04 2022

web may 3 2023 summer reading 10 grade links to short stories a p by pdf pdf partner that we meet the expense of here and check out the link you could buy lead summer reading 10 grade links to short stories a p by pdf pdf or acquire it as soon as feasible you could speedily download this summer reading 10 grade links to short

summer reading 10 grade links to short stories a p by 2022 - Jul 05 2022

web acquire the summer reading 10 grade links to short stories a p by join that we offer here and check out the link you could purchase lead summer reading 10 grade links to short stories a p by or get it as soon as feasible

summer reading 10 grade links to short stories a p by - Sep 19 2023

web pghs quick links summer reading grade 10 9 to 10 summer reading 10 grade links to short stories a p by downloaded from smtp ablogtowatch com by guest burnett colton grade 10 pths summer reading summer reading 10 grade links shelved 2 times as 10th summer reading books goodreadspths summer

10th grade summer reading books goodreads - Apr 14 2023

web showing 1 50 of 64 lord of the flies paperback by william golding shelved 2 times as 10th grade summer reading avg rating 3 69 2 803 919 ratings published 1954 want to read rate this book 1 of 5 stars 2 of 5 stars 3 of 5 stars 4 of 5 stars 5 of 5 stars

summer reading 10 grade links to short stories a p by book - Jul 17 2023

web summer reading 10 grade links to short stories a p by discovering fiction level 1 student s book sep 14 2021 north american short stories enhance students reading skills language learning and enjoyment of literature discovering fiction second edition student s book 1 presents stories

summer reading 10 grade links to short stories a p by pdf - Oct 08 2022

web this info get the summer reading 10 grade links to short stories a p by pdf pdf connect that we manage to pay for here and check out the link you could purchase lead summer reading 10 grade links to short stories a p by pdf pdf or get it as soon as feasible you could quickly download this summer reading 10 grade links to

summer reading 10 grade links to short stories a p by pdf - Sep 07 2022

web jul 27 2023 short stories a p by link that we come up with the money for here and check out the link you could purchase guide summer reading 10 grade links to short stories a p by or acquire it as soon as feasible you could quickly download this summer reading 10 grade links to short stories a p by after getting deal so

summer reading 10 grade links to short stories a p by pdf - Mar 01 2022

web jul 29 2023 summer reading 10 grade links to short stories a p by 2 6 downloaded from uniport edu ng on july 29 2023

by guest summer learning slide and prepare for the grade ahead during the 10 weeks of summer the easy to use full color activities review and extend essential skills and increase confidence at school a test practice

[summer reading 10 grade links to short stories a p by pdf](#) - Apr 02 2022

web apr 25 2023 merely said the summer reading 10 grade links to short stories a p by is universally compatible with any devices to read summer learning headstart grade 5 to 6 fun activities plus math reading and language workbooks

[short stories for 10th grade english synonym](#) - Feb 12 2023

web short stories are essential to any english student s education and they are easily taught and studied teachers can find a variety of short stories written by famous writers to use in class novels can even be excerpted and used as short stories to entice 10th graders to read the entire novel

[summer reading 10 grade links to short stories a p by pdf](#) - Dec 10 2022

web may 30 2023 summer reading 10 grade links to short stories a p by 2 7 downloaded from uniport edu ng on may 30 2023 by guest prepare a child for the grade ahead summer link math plus reading is designed for parents looking for a fun and affordable way to help their children stop the summer learning slide and

[summer reading 10 grade links to short stories a p by pdf](#) - Aug 06 2022

web jan 9 2023 summer reading 10 grade links to short stories a p by 2 10 downloaded from kelliemay com on january 9 2023 by guest love these short illustrated young middle grade books the trilogy is a boy called bat bat and the waiting game and bat and the end of everything

the ultimate summer reading list for kids ages 3 5 brightly - Jan 31 2022

web by max greenfield illustrated by mike lowery this hilarious story is perfect for reluctant readers and book lovers alike many children will find a kindred spirit in the unseen narrator who comically describes his reading challenges with its engaging illustrations and side splitting text this book is irresistible

[summer reading list for a 10 year old the art of simple](#) - May 03 2022

web jun 16 2015 saving lucas biggs thirteen year old margaret knows her father is innocent but that doesn t stop the cruel judge biggs from sentencing him to death margaret is determined to save her dad even if it means using her family s secret and forbidden ability to time travel

[the ultimate summer reading list for ages 8 10 scholastic](#) - Mar 13 2023

web jul 25 2023 ages 8 10 there are endless ways to have summer fun but with the right books reading will be one of your child s go to activities during these more relaxed months maintaining a voracious appetite for reading is especially important for kids ages 8 to 10 according to the 7th edition of the scholastic kids family reading

summer reading 10 grade links to short stories a p by pdf - Jan 11 2023

[waves api 2500 assets wavescdn.com](#) - Aug 02 2023

web the api 2500 is a versatile dynamics processor that lets you shape the punch and tone of mixes with absolute accuracy its dual channel design lets the 2500 also function as two separate mono channels via a single compression setting using auto makeup gain you can adjust threshold or ratio while automatically maintaining a constant output level

[your current opinion of the waves api bundle gearspace.com](#) - Sep 22 2022

web may 8 2017 i still find the waves api 2500 quite useful i did end up getting a hardware 2500 too and it s phenomenal but i don t think waves emulation is bad at least not at lighter settings just this morning i used it on a mix and saw no reason to send that track out of the box to the real 2500 or any other hardware compressor sounded good

[waves api 2500 stereo compressor plug in sweetwater](#) - Apr 29 2023

web only at sweetwater instant delivery and 0 financing for your waves api 2500 stereo compressor plug in console style dynamics processor plug in with 2 x compression types 3 x knee styles and 6 x release settings

[waves api 2500 gearspace.com](#) - Jan 27 2023

web description the api 2500 is a versatile dynamics processor that lets you shape the punch and tone of mixes with absolute accuracy its dual channel design lets the 2500 also function as two separate mono channels via a single compression setting
waves api 2500 owner s manual manualzz - Nov 24 2022

web waves api 2500 user manual 6 type sets the compression type which determines the signal source being fed to the rms detector in rms detector sends a signal to the vca that is an exact ratio of the desired compression set by the ratio control in feeds the vca a signal based on the set signal ratio waves api 2500 user manual

waves api 2500 penny cool studio - Mar 17 2022

web you can find more info and hints about the api 2500 on the uad api 2500 and the plugin alliance lindell sbc and you can compare all of them as well hints i just gave you one above use the knee control play clean and turn off the analog switch you kind of have the perfect world api 2500 where op amps and circuits are really quiet

waves api collection sound on sound - Apr 17 2022

web four plugins are included three are based on classic api eq modules while the fourth emulates the 2500 stereo compressor which was reviewed in its hardware incarnation in sos october 2001 endpoint29cc8e70 chios panth io sos oct01 articles api2500.asp

download waves audio api 2500 gui redesigned free audioz - Feb 25 2023

web sep 12 2020 waves audio api 2500 gui redesigned free audioz skins 1 55 mb here you have the new gui redesigned for api 2500 by waves audio like the real device available for everybody yes it s free

[waves audio api 2500 gui skin v12 updated by pablinimaxd](#) - Oct 24 2022

web aug 30 2021 here you have the new skin for the waves api 2500 only the api 2500 is totally free for everyone tested only with the latest waves v12 release in mac os x catalina attention doesn't work waves v9 v10 or v11 cause the resize feature and the presets navigator is not available in this older versions

waves api 2500 user manual pdf download manualslib - Aug 22 2022

web view and download waves api 2500 user manual online api 2500 music mixer pdf manual download

api 2500 by waves plugins vst au splice - May 19 2022

web the api 2500 is a versatile dynamics processor that lets you shape the punch and tone of mixes with absolute accuracy its dual channel design lets the 2500 also function as two separate mono channels via a single compression setting using auto makeup gain you can adjust threshold or ratio while automatically maintaining a read more

waves api 2500 thomann uk - Jun 19 2022

web waves api 2500 19 compressor plug in download emulation of the api 2500 vintage compressor developed in collaboration with api system requirements version 14 shipping format e mail license validity perpetual copy protection online activation simultaneous activations 1 2 incl active waves update plan windows from 10 64 bit

waves api 2500 owner's manual archive org - Jul 21 2022

web waves api 2500 owner's manual addeddate 2013 11 18 00 48 26 identifier api 2500 owners manual identifier ark ark 13960 t8md18h80 ocr abbyy finereader 9 0 pages 22 ppi 300 plus circle add review comment reviews there are no reviews yet be the first one to write a review