

OPERATION MANUAL

# **YANMAR**

## **MARINE DIESEL ENGINE**

**4LHA-HTP/-HTZP  
4LHA-DTP/-DTZP  
4LHA-STP/-STZP**

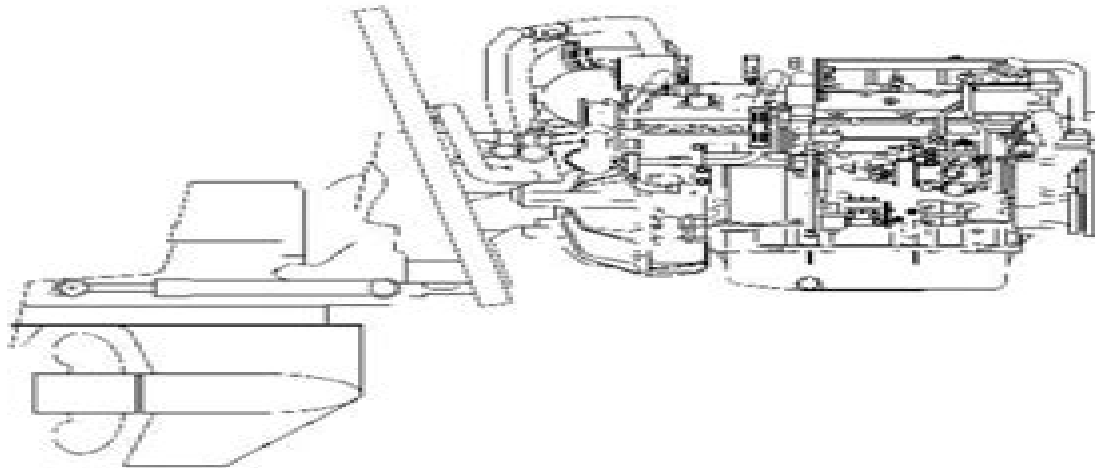

Be sure to read this manual for safe and proper operation.  
Store this manual carefully after use.

# Yanmar 4lha Stp Service Manual

**Oshkosh Truck Corporation**



## **Yanmar 4lha Stp Service Manual:**

Service Manual Caterpillar Tractor Company (U.S.A),1983      **Saab 900 16 Valve Official Service Manual 1985, 1986, 1987, 1988, 1989, 1990, 1991, 1992 1993** Bentley Publishers,1993-06-01 The Saab Official Service Manual 900 16 Valve 1985 1993 contains in depth maintenance service and repair information for Saab 900 16 valve models from 1985 to 1993 This manual also includes coverage of the 1994 900 convertible model The aim throughout has been simplicity and clarity with practical explanations step by step procedures and accurate specifications Whether you re a professional technician or a do it yourself Saab owner this Saab repair manual will help you understand care for and repair your Saab Saab 16 valve models covered Saab Turbo including Saab Turbo SPG 1985 1993 Saab Convertible 1987 1993 Saab 900S 1986 1993 Saab 900 1989 1993 Though the do it yourself Saab owner will find this manual indispensable as a source of detailed maintenance and repair information the Saab owner who has no intention of working on his or her car will find that owning and reading this manual will make it possible to discuss Saab service information repairs more intelligently with a professional technician Features Fundamental automotive concepts explanations of basic troubleshooting safe and effective workshop practices and tools Saab maintenance schedules with procedures from replacing the oxygen sensor to flushing the cooling system This manual tells you what to do how and when to do it and why it s important Detailed in depth troubleshooting and repair information for engine management and emission control systems including Bosch LH 2 2 LH 2 4 and LH 2 4 2 fuel injection EZK and Hall effect ignition systems APC turbocharger knock sensor system Integrated Saab Service and Technical Tips These troubleshooting and repair tips are fast proven procedures used by Saab technicians Critical updates and information from the Saab Service Information Manual the Parts Service Information System and Saab Service Training Comprehensive electrical wiring diagrams broken down into 35 easy to use troubleshooting sections for electrical circuits The information you need to know about a particular circuit is in one place Each section includes a brief circuit description fault tracing fuse relay and component locations as well as component illustrations Publishing note Prior to August 2011 this book was published in a softcover edition ISBN 978 0 8376 0313 1      Service Manual Diamond T Motor Car Company. Service Dept,1948      *Truck Service Manual* ,1984      **Technical Service Manual** American Motors Corporation. Automotive Technical Service,1961      Service Manual Studebaker-Packard Corporation. Packard Division,1955      *Technical Service Manual* American Motors Corporation. Automobile Technical Service,1957      *Subaru Sambar English Service Manual* James Danko,2008-11-17 Over 200 hundred pages of Factory Diagrams and Specifications all Written in English You can rebuild your Samber From the Ground Up Engine Overhaul suspension Brakes Transmission differentials and much more Plus the Factory Electrical Diagrams are also in this book      **Caterpillar 3406e Service Shop Manual 5ek 6ts Cat** ,1999-01-15      Saab 9000 (4-cylinder) A. K. Legg,Spencer Drayton,2001 Hatchback Saloon inc Turbo special limited editions Petrol 2 0 litre 1985cc 2 3 litre 2290cc 4 cyl Does NOT cover V6      Service Manual ,1968

**Motor's Quick Service Manual** Ralph Ritchen,Louis C. Forier,Motor (New York, N.Y.),1967      Service Manual Motor  
Co. Ltd Nissan,197?      **Service Manual [for] R-1234-51812** Oshkosh Truck Corporation,196?      **Saab 9-3 Petrol and  
Diesel Service and Repair Manual** A. K. Legg,2007 Coupe Hatchback Convertible Also covers Convertible models to  
August 2003 Does NOT cover new Saab 9 3 range introduced September 2002 Convertible September 2003 Petrol 2 0 litre  
1985cc 2 3 litre 2290cc inc turbo Turbo Diesel 2 2 litre 2171cc      *Toyota Land Cruiser Automotive Repair Manual* Jeff  
Kibler,Robert Maddox,John Harold Haynes,2002 FJ60 FJ62 F70 F73 F75 F80 FZJ80 with petrol engines      *Technical Service  
Manual: Pacer* American Motors Sales Corporation. Service Publications,1975      **HELP Bumper Service Manual** ,1976  
    **Service Manual** Ulstein Brattvaag AS.,1992      **Radio Service Manual** Atwater Kent Manufacturing Company,1926

Eventually, you will totally discover a other experience and deed by spending more cash. still when? do you admit that you require to get those all needs in imitation of having significantly cash? Why dont you try to get something basic in the beginning? Thats something that will lead you to comprehend even more on the subject of the globe, experience, some places, like history, amusement, and a lot more?

It is your definitely own times to feint reviewing habit. along with guides you could enjoy now is **Yanmar 4lha Stp Service Manual** below.

<https://ftp.barnabastoday.com/data/book-search/index.jsp/thirty%20one%20and%20a%20half%20regrets%20rose%20gardner%20mystery%20volume%204.pdf>

## **Table of Contents Yanmar 4lha Stp Service Manual**

1. Understanding the eBook Yanmar 4lha Stp Service Manual
  - The Rise of Digital Reading Yanmar 4lha Stp Service Manual
  - Advantages of eBooks Over Traditional Books
2. Identifying Yanmar 4lha Stp Service Manual
  - Exploring Different Genres
  - Considering Fiction vs. Non-Fiction
  - Determining Your Reading Goals
3. Choosing the Right eBook Platform
  - Popular eBook Platforms
  - Features to Look for in an Yanmar 4lha Stp Service Manual
  - User-Friendly Interface
4. Exploring eBook Recommendations from Yanmar 4lha Stp Service Manual
  - Personalized Recommendations
  - Yanmar 4lha Stp Service Manual User Reviews and Ratings
  - Yanmar 4lha Stp Service Manual and Bestseller Lists

5. Accessing Yanmar 4lha Stp Service Manual Free and Paid eBooks
  - Yanmar 4lha Stp Service Manual Public Domain eBooks
  - Yanmar 4lha Stp Service Manual eBook Subscription Services
  - Yanmar 4lha Stp Service Manual Budget-Friendly Options
6. Navigating Yanmar 4lha Stp Service Manual eBook Formats
  - ePub, PDF, MOBI, and More
  - Yanmar 4lha Stp Service Manual Compatibility with Devices
  - Yanmar 4lha Stp Service Manual Enhanced eBook Features
7. Enhancing Your Reading Experience
  - Adjustable Fonts and Text Sizes of Yanmar 4lha Stp Service Manual
  - Highlighting and Note-Taking Yanmar 4lha Stp Service Manual
  - Interactive Elements Yanmar 4lha Stp Service Manual
8. Staying Engaged with Yanmar 4lha Stp Service Manual
  - Joining Online Reading Communities
  - Participating in Virtual Book Clubs
  - Following Authors and Publishers Yanmar 4lha Stp Service Manual
9. Balancing eBooks and Physical Books Yanmar 4lha Stp Service Manual
  - Benefits of a Digital Library
  - Creating a Diverse Reading Collection Yanmar 4lha Stp Service Manual
10. Overcoming Reading Challenges
  - Dealing with Digital Eye Strain
  - Minimizing Distractions
  - Managing Screen Time
11. Cultivating a Reading Routine Yanmar 4lha Stp Service Manual
  - Setting Reading Goals Yanmar 4lha Stp Service Manual
  - Carving Out Dedicated Reading Time
12. Sourcing Reliable Information of Yanmar 4lha Stp Service Manual
  - Fact-Checking eBook Content of Yanmar 4lha Stp Service Manual
  - Distinguishing Credible Sources
13. Promoting Lifelong Learning

- Utilizing eBooks for Skill Development
  - Exploring Educational eBooks
14. Embracing eBook Trends
- Integration of Multimedia Elements
  - Interactive and Gamified eBooks

### **Yanmar 4lha Stp Service Manual Introduction**

In today's digital age, the availability of Yanmar 4lha Stp Service Manual books and manuals for download has revolutionized the way we access information. Gone are the days of physically flipping through pages and carrying heavy textbooks or manuals. With just a few clicks, we can now access a wealth of knowledge from the comfort of our own homes or on the go. This article will explore the advantages of Yanmar 4lha Stp Service Manual books and manuals for download, along with some popular platforms that offer these resources. One of the significant advantages of Yanmar 4lha Stp Service Manual books and manuals for download is the cost-saving aspect. Traditional books and manuals can be costly, especially if you need to purchase several of them for educational or professional purposes. By accessing Yanmar 4lha Stp Service Manual versions, you eliminate the need to spend money on physical copies. This not only saves you money but also reduces the environmental impact associated with book production and transportation. Furthermore, Yanmar 4lha Stp Service Manual books and manuals for download are incredibly convenient. With just a computer or smartphone and an internet connection, you can access a vast library of resources on any subject imaginable. Whether you're a student looking for textbooks, a professional seeking industry-specific manuals, or someone interested in self-improvement, these digital resources provide an efficient and accessible means of acquiring knowledge. Moreover, PDF books and manuals offer a range of benefits compared to other digital formats. PDF files are designed to retain their formatting regardless of the device used to open them. This ensures that the content appears exactly as intended by the author, with no loss of formatting or missing graphics. Additionally, PDF files can be easily annotated, bookmarked, and searched for specific terms, making them highly practical for studying or referencing. When it comes to accessing Yanmar 4lha Stp Service Manual books and manuals, several platforms offer an extensive collection of resources. One such platform is Project Gutenberg, a nonprofit organization that provides over 60,000 free eBooks. These books are primarily in the public domain, meaning they can be freely distributed and downloaded. Project Gutenberg offers a wide range of classic literature, making it an excellent resource for literature enthusiasts. Another popular platform for Yanmar 4lha Stp Service Manual books and manuals is Open Library. Open Library is an initiative of the Internet Archive, a non-profit organization dedicated to digitizing cultural artifacts and making them accessible to the public. Open Library hosts millions of books, including both public domain works and contemporary titles. It

also allows users to borrow digital copies of certain books for a limited period, similar to a library lending system. Additionally, many universities and educational institutions have their own digital libraries that provide free access to PDF books and manuals. These libraries often offer academic texts, research papers, and technical manuals, making them invaluable resources for students and researchers. Some notable examples include MIT OpenCourseWare, which offers free access to course materials from the Massachusetts Institute of Technology, and the Digital Public Library of America, which provides a vast collection of digitized books and historical documents. In conclusion, Yanmar 4lha Stp Service Manual books and manuals for download have transformed the way we access information. They provide a cost-effective and convenient means of acquiring knowledge, offering the ability to access a vast library of resources at our fingertips. With platforms like Project Gutenberg, Open Library, and various digital libraries offered by educational institutions, we have access to an ever-expanding collection of books and manuals. Whether for educational, professional, or personal purposes, these digital resources serve as valuable tools for continuous learning and self-improvement. So why not take advantage of the vast world of Yanmar 4lha Stp Service Manual books and manuals for download and embark on your journey of knowledge?

## **FAQs About Yanmar 4lha Stp Service Manual Books**

1. Where can I buy Yanmar 4lha Stp Service Manual books? Bookstores: Physical bookstores like Barnes & Noble, Waterstones, and independent local stores. Online Retailers: Amazon, Book Depository, and various online bookstores offer a wide range of books in physical and digital formats.
2. What are the different book formats available? Hardcover: Sturdy and durable, usually more expensive. Paperback: Cheaper, lighter, and more portable than hardcovers. E-books: Digital books available for e-readers like Kindle or software like Apple Books, Kindle, and Google Play Books.
3. How do I choose a Yanmar 4lha Stp Service Manual book to read? Genres: Consider the genre you enjoy (fiction, non-fiction, mystery, sci-fi, etc.). Recommendations: Ask friends, join book clubs, or explore online reviews and recommendations. Author: If you like a particular author, you might enjoy more of their work.
4. How do I take care of Yanmar 4lha Stp Service Manual books? Storage: Keep them away from direct sunlight and in a dry environment. Handling: Avoid folding pages, use bookmarks, and handle them with clean hands. Cleaning: Gently dust the covers and pages occasionally.
5. Can I borrow books without buying them? Public Libraries: Local libraries offer a wide range of books for borrowing. Book Swaps: Community book exchanges or online platforms where people exchange books.



6. How can I track my reading progress or manage my book collection? Book Tracking Apps: Goodreads, LibraryThing, and Book Catalogue are popular apps for tracking your reading progress and managing book collections. Spreadsheets: You can create your own spreadsheet to track books read, ratings, and other details.
7. What are Yanmar 4lha Stp Service Manual audiobooks, and where can I find them? Audiobooks: Audio recordings of books, perfect for listening while commuting or multitasking. Platforms: Audible, LibriVox, and Google Play Books offer a wide selection of audiobooks.
8. How do I support authors or the book industry? Buy Books: Purchase books from authors or independent bookstores. Reviews: Leave reviews on platforms like Goodreads or Amazon. Promotion: Share your favorite books on social media or recommend them to friends.
9. Are there book clubs or reading communities I can join? Local Clubs: Check for local book clubs in libraries or community centers. Online Communities: Platforms like Goodreads have virtual book clubs and discussion groups.
10. Can I read Yanmar 4lha Stp Service Manual books for free? Public Domain Books: Many classic books are available for free as they're in the public domain. Free E-books: Some websites offer free e-books legally, like Project Gutenberg or Open Library.

### Find Yanmar 4lha Stp Service Manual :

*thirty one and a half regrets rose gardner mystery volume 4*

*they cage the animals at night signet*

*things that only god can explain*

*thomson tv service manual free*

*thomas pynchon and american counterculture cambridge studies in american literature and culture*

*thinkers 50 innovation breakthrough thinking to take your business to the next level*

***thousand character classic for english readers***

*thor god of thunder godbomb*

*three mothers three daughters palestinian womens stories literature of the middle east*

*third grade fill in the blank*

*thousand years of stained glass*

*thomas kinkade special collectors edition with scripture 2016 deluxe wall calen mountain majesty*

*thomson tg585 cli manual*

**this business of music 10th edition**

this happened to me a graphic collection of true adventure tales

**Yanmar 4lha Stp Service Manual :**

**download solutions practice questions on vernier calipers** - Sep 06 2022

web practice questions on vernier calipers s chand s icse physics book 1 for class ix jul 11 2020 icse physics book ii for class ix comprehensive basic mechanical engineering mar 19 2021 longman 1001 physics mcqs for o level oct 18 2023 this book is written for the latest physics gce o level syllabus

**physics practical class 11 viva questions to measure the** - Nov 27 2021

web answer calliper is a device used to measure the dimensions of an object what are the scales in a vernier calliper answer scales on a vernier callipers are the main scale and a vernier scale what is the least count of vernier calliper also known as answer the least count of vernier calliper is also known as the vernier constant

**c iit jee physics concepts of physics** - Aug 05 2022

web in class 11th physics lab we were trained to answer the following questions how to nd the least count lc or vernier constant how to read main scale reading msr and vernier scale reading vsr how to nd the zero error

vernier calliper questions practice questions with answers - Sep 18 2023

web practice questions what is meant by a calliper what is a vernier calliper the external size of an object is measured using which type of callipers what is the main function of the thumbscrew which jaw is used to measure the internal diameter of an object

**vernier calipers questions answers for interview** - Jan 30 2022

web vernier calipers questions and answers frequently asked questions and answers of vernier calipers in optics of physics to enhance your skills knowledge on the selected topic we have compiled the best vernier calipers interview question and answer trivia quiz mcq questions viva question quizzes to prepare

**practice questions on vernier calipers** - Aug 17 2023

web practice questions on vernier calipers understanding physics for jee main and advanced mechanics part 1 apr 16 2020 1 understanding physics series comprises of total 5 books 2 total 36 essential chapters of physics 3 volume 1 is mechanics part 1 consists 10 chapters 4 includes last 6 years question of jee main advances 5

vernier calliper definition diagram least count parts - Jun 03 2022

web linear motion physics vernier calliper is defined as a measuring device that is used for measuring linear dimensions and dimensions such as inner and outer diameters and depths of an object learn about the least count of vernier calliper

applications and how to read vernier calliper here

**vernier calipers 2 1k plays quizizz** - Jun 15 2023

web vernier calipers quiz for 6th grade students find other quizzes for physics and more on quizizz for free

*vernier caliper worksheet with example solution* - Jul 16 2023

web vernier caliper worksheet vernier caliper worksheet q1 what is the reading on the vernier scales below the scale is in metric units i ii iii iv v q2 find the readings

*metric vernier caliper practice sheets weldnotes com* - Jan 10 2023

web jan 27 2017 by bobwelds published january 27 2017 updated may 11 2018 reading a vernier micrometer takes practice we put together some practice pages with and without answers there are two versions a shaded one that is more realistic and a non shaded one that is easier to read

**how to use a vernier caliper tips for measuring and reading wikihow** - Feb 11 2023

web jul 23 2023 1 locate both sets of jaws and measuring scales on your caliper a vernier caliper has large jaws that are used for measuring an object's external diameter as well as smaller jaws that are used for measuring the internal diameter there are also two scales

**practice on reading a vernier caliper mini physics** - Oct 19 2023

web feb 1 2015 find the readings of the vernier calipers below if you encounter any difficulties or have forgotten how to read a vernier caliper you can visit how to read a vernier caliper

**what is vernier calipers and how it is used for measurement** - Feb 28 2022

web jul 30 2019 vernier calipers are tools which attain that much required accuracy the vernier scale was created in 1631 by french mathematician pierre vernier to obtain measurements more exactly than a usual measuring scale calipers are measuring objects which can grasp the thing to be measured and give a study which depends on the

**vernier caliper definition measurement and zero error** - Apr 01 2022

web zero error in vernier caliper practice problems of vernier caliper faqs of vernier caliper vernier caliper to measure length up to we can use vernier caliper it consists of three parts main scale m it is a steel metallic strip graduated in cm and mm at one edge it carries two fixed jaws m 1 and m 2 vernier scale v

**practice on reading a vernier caliper with zero error** - May 14 2023

web feb 1 2015 practice on reading a vernier caliper with zero error the top image depicts the vernier caliper with its jaws tightly closed while the bottom image depicts the vernier caliper with its jaws closed on an object find the zero error and the correct reading of the vernier calipers below

**how to read a vernier caliper mini physics learn physics** - Apr 13 2023

web nov 13 2014 a quick guide on how to read a vernier caliper a vernier caliper outputs measurement readings in centimetres cm and it is precise up to 2 decimal places e g 1 23 cm note the measurement reading technique described in this post will be similar for vernier calipers which output measurement readings in inches

**vernier caliper worksheet with example solution answers** - Dec 09 2022

web vernier caliper worksheet is an example test paper for students the question is stated in this manner as stated in our article example the first question has been solved as an example to demonstrate the procedure and refresh your memory on how to read the vernier calipers scale step 1

practice on finding the zero error of a vernier caliper - Nov 08 2022

web feb 1 2015 vernier caliper practice with zero error assuming that the jaws of the vernier calipers are tightly closed find the zero error of the vernier calipers below if you encounter any difficulties or have forgotten how to read a vernier caliper you can visit how to read a vernier caliper

*free caliper vernier measurement questions and answers* - May 02 2022

web free caliper vernier measurement questions and answers the red line indicates the coinciding lines what measurement do you have 38 cm 15 46 mm 38 mm 15 46 cm

vernier caliper st lawrence university physics - Mar 12 2023

web practice using the vernier caliper by measuring the length inner diameter and outer diameter of the plastic pipe provided check your measurements with your lab partner if there is disagreement read the vernier scale again be sure to ask your instructor if you are still unsure of the correct procedure

*vernier calliper questions and answers topperlearning* - Jul 04 2022

web ask your doubt of vernier calliper and get answer from subject experts and students on topperlearning

*14 vernier calipers screw gauge for neet 2024 unacademy* - Dec 29 2021

web nov 19 2023 vishal sharma this video presents you with an essential foundation in torque for physics focusing specifically on neet 2024 25 whether you re a student pursuing physics or simply interested in understanding the units dimensions and its concepts that underpin the subject this video is tailored to meet your needs by vishal

**vernier caliper practice problems orientation sutd edu** - Oct 07 2022

web need to take the caliper profile as part of a hiring process jobtestprep offers simulated practice questions and tips to help prepare you for your assessment how to solve the numerical on vernier callipers question is in a vernier callipers 19 main scale divisions coincides with 20 vernier scale divisions if the main scale has 20

*schede didattiche di inglese per la classe quinta* - Aug 23 2022

web jul 10 2020 completiamo la nostra raccolta di materiale didattico in lingua inglese e in particolare lo faremo andando a

mettervi a disposizione tutte le schede didattiche di cui avrete bisogno per accompagnare gli studenti della quinta classe della scuola primaria nello studio della lingua anglosassone abbiamo realizzato una utilissima raccolta di esercizi

**schede didattiche inglese scuola infanzia cinque sensi 2023** - Mar 18 2022

web schede didattiche inglese scuola infanzia cinque sensi 1 schede didattiche inglese scuola infanzia cinque sensi clil with lapbook science classe terza spontaneous activity in education giornale della libreria i bambini e le lingue dyslexia what is it uno studio teorico e pratico sull insegnamento della lingua inglese agli studenti dislessici

*schede didattiche inglese scuola infanzia cinque sensi* - Sep 04 2023

web schede didattiche inglese scuola infanzia cinque sensi gli ebook raccolgono le nostre schede didattiche insieme ai link alle migliori risorse web particolarmente utili per l uso della lim e per la navigazione individuale clicca

5 sensi in inglese per bambini della scuola primaria open minds - Oct 05 2023

web 5 sensi in inglese per bambini della scuola primaria ti trovi qui home inglese scuola primaria 5 sensi in inglese per bambini 24 dicembre 2020 by claudia adamo 8 comments in questa pagina puoi scaricare un bellissimo progetto di soft clil sui 5 sensi creato dai nostri teachers madrelingua

i cinque sensi in inglese scuola primaria archivi jack potato - Nov 25 2022

web un clil di scienze sui cinque sensi è la proposta jack potato di oggi consiste in una raccolta di 5 schede da utilizzare come supporto per condurre più lezioni di scienze in lingua inglese suddivise in vista udito olfatto tatto e gusto

*usiamo i 5 sensi anzi 6 per insegnare l inglese ai bambini buzzy english* - Jul 02 2023

web mar 20 2019 usiamo i cinque sensi per imparare l inglese meglio ancora avviciniamo l inglese ai bambini coinvolgendo i loro cinque sensi così che il bambino possa vedere e leggere vista udire udito pronunciare gusto toccare tatto e perché no odorare le parole e le frasi della lingua inglese una follia davvero

*i cinque sensi in inglese kidsandus* - Aug 03 2023

web mar 24 2022 per imparare l inglese con i cinque sensi e tutto il vocabolario relativo non c è niente di meglio che utilizzare per l appunto i cinque sensi vogliamo quindi proporvi giochi e attività che vi aiuteranno ad attivare tutti i sensi e metterli al servizio dell apprendimento dell inglese

alla scoperta dei 5 sensi asilonidolacasadellefate it - Sep 23 2022

web alla scoperta dei 5 sensi il bambino non impara ma costruisce il suo sapere attraverso l esperienza e le relazioni con l ambiente che lo circonda maria montessori premessa il progetto sensoriale nasce dal desiderio di accompagnare i bambini alla scoperta dei cinque sensi con l intento di favorire sia l acquisizione di

i cinque sensi schede didattiche per la classe prima - May 20 2022

web apr 15 2019 pdf schede didattiche sui cinque sensi schede didattiche da stampare singolarmente grazie alla galleria

che segue potrete invece stampare i singoli esercizi scegliendo soltanto quelli di vostro interesse tra i diversi proposti  
schede didattiche inglese scuola infanzia cinque sensi - Jul 22 2022

web schede didattiche inglese scuola infanzia cinque sensi buone pratiche nella scuola e suggerisce risorse e materiali presenti in rete ed utili per la didattica schede e attività di scienze maestrabry april 30th 2018 schede e attività di scienze per la scuola primaria noidellalampedusa april 27th 2018 il saluto del dirigente scolastico  
*i cinque sensi le schede fantavolando* - Mar 30 2023

web bambini della scuola dell'infanzia 5 anni bambini della scuola primaria classe prima questa attività favorisce la conoscenza dei cinque sensi materiale occorrente fogli a4 pastelli procediamo come segue leggiamo le consegne e invitiamo i bambini a completare le schede didattiche

schede didattiche inglese scuola infanzia cinque sensi - Jan 28 2023

web schede didattiche inglese scuola infanzia cinque sensi insegnamento nelle primarie e all'infanzia ente accreditato e qualificato che offre formazione al personale della scuola d m 177 2000 direttiva n 90 del 2003 confluite nella direttiva 170 del 21 03 2016 gli ebook raccolgono le nostre schede didattiche insieme ai link alle migliori risorse

**schede didattiche inglese scuola infanzia cinque sensi pdf** - Feb 26 2023

web schede didattiche inglese scuola infanzia cinque sensi quale futuro per la scuola pubblica jan 03 2021 la professione dell'insegnante è senza dubbio una delle esperienze più stimolanti il solo avere consapevolezza che il tuo rapporto col bambino o con il ragazzo avrà comunque una qualche influenza

**schede didattiche inglese scuola infanzia cinque sensi** - Apr 18 2022

web schede e attività di scienze maestrabry home euroedizioni it ebook wikipedia ciao bambini i cinque sensi olfatto tatto udito vista ciao bambini i cinque sensi la vista ciaomaestra com esempi di nomi astratti e concreti online kptm edu my 6 57

**schede didattiche di inglese pianetabambini it** - Jun 20 2022

web dec 14 2022 tante schede didattiche di inglese per bambini della scuola dell'infanzia e di tutte le classi della scuola primaria in pdf pronte da stampare gratis didattica accoglienza

**la maestra linda i 5 sensi blogger** - Apr 30 2023

web pregrafismi numeri primi giorni di scuola i 5 sensi i numeri da 1 a 9 i 4 elementi educazione stradale cappuccetto rosso benvenuti e bentornati alla scuola dell'infanzia bentornata estate striscione accoglienza e primi giorni di scuola  
*imparare i cinque sensi in modo divertente a scuola con agnes* - Oct 25 2022

web la raccolta di schede sui cinque sensi include giochi interattivi che rendono l'apprendimento dei 5 sensi divertente ed allo stesso tempo facile per i bambini all'interno delle schede potrai trovare esercizi che comprendono tatto vista olfatto udito e gusto

**attività in inglese sui cinque sensi il blog dell inglese per i bambini** - Jun 01 2023

web feb 23 2015 1 nominare i sensi in modo corretto i bambini conoscono i nomi corretti dei sensi in italiano li sanno distinguere per aiutarci in questa prima fase possiamo utilizzare un poster che illustra i sensi con una grafica chiara e adatta ai bambini

*schede didattiche inglese scuola infanzia cinque sensi* - Feb 14 2022

web schede didattiche inglese scuola infanzia cinque sensi allegretti ciao bambini i cinque sensi olfatto tatto udito vista april 30th 2018 i cinque sensi schede didattiche e risorse dal web per la classe 1 della scuola primaria e la scuola dell infanzia nomi sensi pdf senso vista pdf senso tatto pdf senso olfatto pdf

*schede didattiche inglese scuola primaria scarica pdf riscrivibili* - Dec 27 2022

web qui potete scaricare la scheda inerenti i numeri in inglese per bambini della scuola di infanzia e primaria si tratta di una raccolta di schede in pdf nelle quali potete trovare esercizi sui singolari plurali esercizi di matching numero scritto in cifre nome del numero e esercizi per praticare lo spelling dei nomi dei numeri che sono tricky words e quindi

**fundamentals of power system economics solution manual pdf** - Jul 26 2022

web discusses the effects of the increased uncertainty on system operation broadens its coverage of transmission investment and generation investment supports self study with end of chapter problems and instructors with solutions manual via companion website

**fundamentals of power system economics solution manual pdf** - Oct 29 2022

web view fundamentals of power system economics solution manual pdf from mbad 5113m at university of north carolina charlotte fundamentals of power system economics solution manual getting the books

*fundamentals of power system economics* - May 24 2022

web fundamentals of power system economics daniel kirschen goran strbac university of manchester institute of science technology umist uk 047002058x jpg fundamentals of power have been written to discuss these new issues and to propose solutions the objective of this book is not to summarize or repeat what is in these

**fundamentals of power system economics wiley online books** - Jun 05 2023

web mar 26 2004 about this book interest in power systems economics is gaining momentum with the recent power supply shortages in america and the rising cost of fossil fuels the involvement of independent power generators brokers and distributors has changed the way in which power systems operate

*fundamentals of power system economics google books* - Jun 24 2022

web oct 22 2004 fundamentals of power system economics daniel s kirschen goran strbac john wiley sons oct 22 2004 technology engineering 304 pages interest in power systems economics is gaining

**fundamentals of power system economics 2nd edition wiley** - Dec 31 2022

web description a new edition of the classic text explaining the fundamentals of competitive electricity markets now updated to reflect the evolution of these markets and the large scale deployment of generation from renewable energy sources

[fundamentals of power system economics 2nd edition wiley](#) - Jul 06 2023

web this extensively revised and updated edition of the classic text on power system economics explains the basic economic principles underpinning the design operation and planning of modern power systems in a competitive environment

**fundamentals of power system economics google books** - Mar 22 2022

web jul 4 2018 fundamentals of power system economics second edition looks at the fundamental concepts of microeconomics organization and operation of electricity markets market participants strategies

**fundamentals of power system economics solutions manual chegg** - Aug 07 2023

web get instant access to our step by step fundamentals of power system economics solutions manual our solution manuals are written by chegg experts so you can be assured of the highest quality

**fundamentals of power system economics 2nd edition wiley** - Feb 01 2023

web welcome to the web site for fundamentals of power system economics 2nd edition by daniel s kirschen goran strbac this web site gives you access to the rich tools and resources available for this text you can access these resources in two ways using the menu at the top select a chapter a list of resources available for that particular

**fundamentals of power system economics solution manual issuu** - Sep 27 2022

web sep 4 2017 read fundamentals of power system economics solution manual by josefaresendez3804 on issuu and browse thousands of other publications on our platfo

**solution manual fundamentals of power system economics 2nd** - Aug 27 2022

web jan 26 2021 solution manual engineering mathematics a foundation for electronic electrical communications and systems engineers 4th ed anthony croft robert davison martin hargreaves james flint solution manual fundamentals of high frequency cmos analog integrated circuits duran leblebici yusuf leblebici

[ee553 power system economics winter 2023 github pages](#) - Sep 08 2023

web class syllabus we will define and discuss the major problems in power system economics optimization problem formulations and solutions competition bidding strategies locational marginal prices ancillary services and investment decisions for more information see syllabus this is the main website for this class

[kirschen strbac fundamentals of power system economics](#) - Nov 29 2022

web kirschen strbac fundamentals of power system economics 2nd edition home browse by chapter browse by chapter

[fundamentals of power system economics cern](#) - Mar 02 2023



web 4 2 1 retailers of electrical energy 75 4 3 the producer's perspective 79 4 3 1 perfect competition 80 4 3 2  
the production versus purchase decision 88 4 3 3 imperfect competition 90 4 4 perspective of plants with very low marginal costs  
99 4 5 the hybrid participant's perspective 99 4 6 further reading 101 4 7 problems 102

[economics of power systems fundamentals for sustainable energy](#) - Feb 18 2022

web provides an overview of the key economic technological and environmental drivers for power systems introduces readers to major economic models for the study of electricity markets and systems discusses policy instruments and design choices for electricity market regulation

**fundamentals of power system economics open library** - Apr 22 2022

web oct 4 2021 0 have read interest in power systems economics is gaining momentum with the recent power supply shortages in america and the rising cost of fossil fuels the involvement of independent power generators brokers and distributors has changed the way in which power systems operate

**fundamentals of power system economics 2nd edition wiley** - Apr 03 2023

web system economics explains the basic economic principles underpinning the design operation and planning of modern power systems in a competitive environment it also discusses the economics of renewable energy sources in electricity markets the provision of incentives and the cost of integrating renewables in the grid fundamentals of power

**fundamentals of power system economics wiley** - May 04 2023

web description interest in power systems economics is gaining momentum with the recent power supply shortages in america and the rising cost of fossil fuels the involvement of independent power generators brokers and distributors has changed the way in which power systems operate

**appendix answers to selected problems fundamentals of power system** - Oct 09 2023

web mar 26 2004 free access appendix answers to selected problems book author's daniel kirschen goran strbac first published 26 march 2004