

Model without mounting flange

a) Clockwise rotation b) Oil dipstick and filter screw 17mm c) M 8/12 deep, holes same on both sides d) Oil drain plug 17mm width across flats e) Spline profile similar B 10x23x29 DIN 5464 f) Minimum lever travel

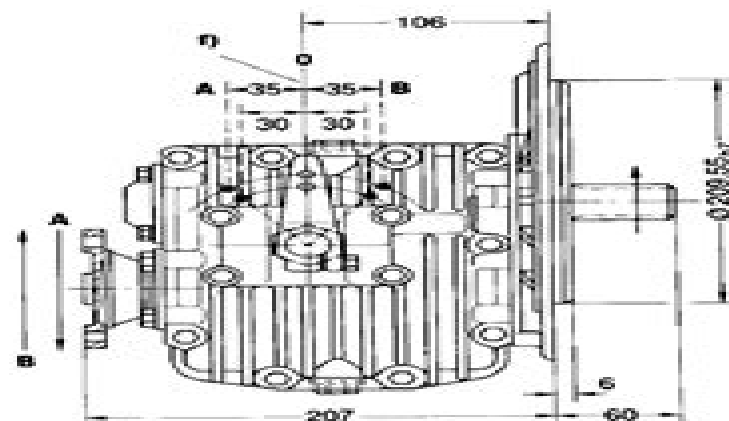
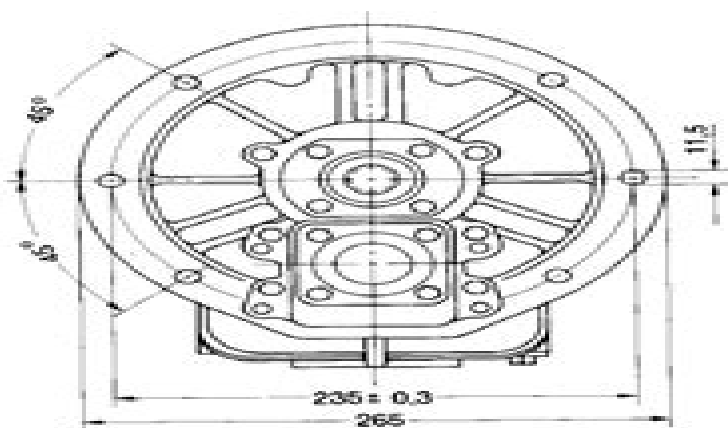

Model with mounting flange

Zf 2000 Gearbox Manual

Rosina Ehmann



Zf 2000 Gearbox Manual:

Rover P6: 2000, 2200, 3500 James Taylor, 2020-04-20 The Rover P6 was unquestionably one of the best saloon cars to come out of Britain in the 1960s and was winner of the first ever European Car of the Year award It combined a wealth of technical innovation with a distinctive appearance that incorporated exactly the right degree of Italianate sharp suited appearance for its time It was and remains a great car to drive and all these qualities were combined with the space and practicality of a four seat family saloon Rover P6 2000 2200 3500 The Complete Story documents its evolution from the earliest ideas in the 1950s to the end of production in 1977 It describes all the models with specification tables and paint and trim options including NADA and Federal cars and remembers the motorsport successes and failures It records the manufacturing process at Solihull and CKD overseas and includes a useful chapter on buying and owning a Rover P6

Automotive Transmissions Harald Naunheimer, Bernd Bertsche, Joachim Ryborz, Wolfgang Novak, 2010-11-09 This book gives a full account of the development process for automotive transmissions Main topics Overview of the traffic vehicle transmission system Mediating the power flow in vehicles Selecting the ratios Vehicle transmission systems basic design principles Typical designs of vehicle transmissions Layout and design of important components e g gearshifting mechanisms moving off elements pumps retarders Transmission control units Product development process Manufacturing technology of vehicle transmissions Reliability and testing The book covers manual automated manual and automatic transmissions as well as continuously variable transmissions and hybrid drives for passenger cars and commercial vehicles Furthermore final drives power take offs and transfer gearboxes for 4 WD vehicles are considered Since the release of the first edition in 1999 there have been a lot of changes in the field of vehicles and transmissions About 40% of the second edition s content is new or revised with new data *BMW Classic Coupes, 1965 - 1989* James Taylor, 2014-11-30 A definitive guide to BMW s high performance classic coupes tracking their rising success from 1965 to 1989 After the doldrums of the post war years BMW had felt the need for a flagship grand touring coupe The 507 of the late 1950s and the 3200 CS that replaced it in the early 1960s may not have made much money for the company but they were a reminder of its aspirations Then in 1964 a striking new coupe emerged from the building blocks of the latest saloon car range The 2000 and 2000 CS with their feisty 2 litre 4 cylinder engines were the affordable foundation on which BMW was able to build its next generation of coupes and what formidable machines those were This definitive guide covers BMW s high performance classic coupes tracking their rising success from 1965 to 1989 and includes full specification guides production histories and original photography Topics covered include BMW s hand built coupes of the 1950s and the first volume built models the mainstream E9 range with new engines and revised front end styling racing success for the Batmobile CSLs including six wins at the European Touring Car Championship from 1973 to 1979 engineering and development of the luxury E24 range tuned and modified coupes including the rare custom convertibles Fully illustrated with 234 colour photographs *Standard Catalog of Imported Cars,*

1946-1990 James M. Flammang,1992 This book provides a wealth of detailed information that collectors investors and restorers of imported cars will not find in any other book This massive volume spans the marques of imported vehicles The list includes such familiar names as Alfa Romeo Aston Martin Bentley Citroen Jaguar Lamborghini Porsche Rolls Royce Saab and Volkswagon Also in these pages you ll find details on such lesser known yet no less intriguing marques as Abarth DAF Frazer Nash Humber Iso Nardi Panhard Peerless Sabra and Skoda The book also highlights model changes and corporate histories and provides value information on the most popular models of imported cars

Land Rover Discovery James Taylor,2014-04-30 A quarter of a century ago the Land Rover Discovery defined at a stroke how traditional 4 x 4 all terrain ability could co exist with family estate practicality at an affordable price Since 1989 the Discovery has gone through several iterations but its essential qualities have remained unchanged Practical capable and above all completely distinctive the stepped roof seemed odd at first but now defines the Discovery shape the Discovery has gone on to become one of Land Rover s best loved products Land Rover Discovery 25 Years of the Family 4 x 4 looks in detail at the four generations of Discovery including full specification details and production histories Topics covered include the design and development of the original Discovery in the late 1980s and the move into North America the new 300Tdi engine and R380 gearbox of 1994 and the BMW takeover Series II models of 1998 2004 and Land Rover s move from BMW to Ford Discovery 3 LR3 2004 2009 and the new TDV6 engine developed by Jaguar Discovery 4 LR4 the all purpose family luxury car special editions and derivatives of all four generations of Discovery including Discoverys for the emergency services and the Camel Trophy and G4 Challenge competition vehicles Superbly illustrated with 351 colour photographs

Standard Catalog of Imported Cars 1946-2002 Mike Covello,2001-10-01 This is the only book that completely lists accurate technical data for all cars imported into the U S market from 1946 2000 With many imports approaching the antique status this book will be a big seller across all generations of car enthusiasts From the grandiose European carriages of the late Forties to the hot little Asian imports of the Nineties every car to grace American roadways from across the Atlantic and Pacific is carefully referenced in this book Foreign car devotees will appreciate the attention given to capturing precise data on Appearance and Equipment Vehicle I D Numbers Specification Charts Engine Data Chassis Technical Data Options and Historical Information Collectors restorers and car buffs will love this key book from noted automotive authors James Flammang and Mike Covello

Motor Cycling and Motoring ,1987 World Car Catalogue ,1971 Automobile Engineer ,1967 Land Rover Freelander James Taylor,2017-06-30 Land Rover Freelander The Complete Story recounts the history of the Land Rover Freelander and its popular successor the Freelander 2 This new book covers the original Freelander from its design and development to its launch and reception in 1997 In 2006 the innovative Freelander 2 was launched with its pioneering technology in fuel efficiency Also covered are the Freelander variants from across the world and its use in UK law enforcement This is an indispensable guide to the history of both generations of Freelander and is aimed at enthusiasts of

Land Rover throughout the world Lavishly illustrated with 284 colour photographs **Range Rover Second Generation**
James Taylor,2018-09-23 The second generation Range Rover was arguably Land Rover s first model designed as a luxury
vehicle It was a major leap for the company but a very successful one as well Despite controversy over its looks and some
initial teething problems it became a worthy successor to the much loved original Range Rover Second Generation The
Complete Story draws on the memories of designers and engineers as well as on a wide variety of factory sources to provide
the most authoritative history of the mode yet The book covers the full development history the changes during eight years of
production Range Rovers for the North American market full technical specifications and finally Range Rovers and the
emergency services A companion volume to the author s Range Rover First Generation The Complete Story Crowood 2018
The Automobile Engineer ,1967 **Automotive Industries** ,1999 **Autocar & Motor** ,1994-07 The Rover Story
Graham Robson,1981 World Cars ,1985 **Automobile Quarterly** ,1997 **Motor Industry Magazine** ,2005-02
Marine Propulsion & Auxiliary Machinery ,2005 *Technical Service Data* ,1969

Ignite the flame of optimism with Get Inspired by is motivational masterpiece, Fuel Your Spirit with **Zf 2000 Gearbox Manual** . In a downloadable PDF format (PDF Size: *), this ebook is a beacon of encouragement. Download now and let the words propel you towards a brighter, more motivated tomorrow.

https://ftp.barnabastoday.com/book/virtual-library/Download_PDFS/Think_And_Grow_Rich_10_Cd_Set.pdf

Table of Contents Zf 2000 Gearbox Manual

1. Understanding the eBook Zf 2000 Gearbox Manual
 - The Rise of Digital Reading Zf 2000 Gearbox Manual
 - Advantages of eBooks Over Traditional Books
2. Identifying Zf 2000 Gearbox Manual
 - Exploring Different Genres
 - Considering Fiction vs. Non-Fiction
 - Determining Your Reading Goals
3. Choosing the Right eBook Platform
 - Popular eBook Platforms
 - Features to Look for in an Zf 2000 Gearbox Manual
 - User-Friendly Interface
4. Exploring eBook Recommendations from Zf 2000 Gearbox Manual
 - Personalized Recommendations
 - Zf 2000 Gearbox Manual User Reviews and Ratings
 - Zf 2000 Gearbox Manual and Bestseller Lists
5. Accessing Zf 2000 Gearbox Manual Free and Paid eBooks
 - Zf 2000 Gearbox Manual Public Domain eBooks
 - Zf 2000 Gearbox Manual eBook Subscription Services
 - Zf 2000 Gearbox Manual Budget-Friendly Options
6. Navigating Zf 2000 Gearbox Manual eBook Formats

- ePub, PDF, MOBI, and More
 - Zf 2000 Gearbox Manual Compatibility with Devices
 - Zf 2000 Gearbox Manual Enhanced eBook Features
7. Enhancing Your Reading Experience
 - Adjustable Fonts and Text Sizes of Zf 2000 Gearbox Manual
 - Highlighting and Note-Taking Zf 2000 Gearbox Manual
 - Interactive Elements Zf 2000 Gearbox Manual
 8. Staying Engaged with Zf 2000 Gearbox Manual
 - Joining Online Reading Communities
 - Participating in Virtual Book Clubs
 - Following Authors and Publishers Zf 2000 Gearbox Manual
 9. Balancing eBooks and Physical Books Zf 2000 Gearbox Manual
 - Benefits of a Digital Library
 - Creating a Diverse Reading Collection Zf 2000 Gearbox Manual
 10. Overcoming Reading Challenges
 - Dealing with Digital Eye Strain
 - Minimizing Distractions
 - Managing Screen Time
 11. Cultivating a Reading Routine Zf 2000 Gearbox Manual
 - Setting Reading Goals Zf 2000 Gearbox Manual
 - Carving Out Dedicated Reading Time
 12. Sourcing Reliable Information of Zf 2000 Gearbox Manual
 - Fact-Checking eBook Content of Zf 2000 Gearbox Manual
 - Distinguishing Credible Sources
 13. Promoting Lifelong Learning
 - Utilizing eBooks for Skill Development
 - Exploring Educational eBooks
 14. Embracing eBook Trends
 - Integration of Multimedia Elements
 - Interactive and Gamified eBooks

Zf 2000 Gearbox Manual Introduction

Free PDF Books and Manuals for Download: Unlocking Knowledge at Your Fingertips In today's fast-paced digital age, obtaining valuable knowledge has become easier than ever. Thanks to the internet, a vast array of books and manuals are now available for free download in PDF format. Whether you are a student, professional, or simply an avid reader, this treasure trove of downloadable resources offers a wealth of information, conveniently accessible anytime, anywhere. The advent of online libraries and platforms dedicated to sharing knowledge has revolutionized the way we consume information. No longer confined to physical libraries or bookstores, readers can now access an extensive collection of digital books and manuals with just a few clicks. These resources, available in PDF, Microsoft Word, and PowerPoint formats, cater to a wide range of interests, including literature, technology, science, history, and much more. One notable platform where you can explore and download free Zf 2000 Gearbox Manual PDF books and manuals is the internet's largest free library. Hosted online, this catalog compiles a vast assortment of documents, making it a veritable goldmine of knowledge. With its easy-to-use website interface and customizable PDF generator, this platform offers a user-friendly experience, allowing individuals to effortlessly navigate and access the information they seek. The availability of free PDF books and manuals on this platform demonstrates its commitment to democratizing education and empowering individuals with the tools needed to succeed in their chosen fields. It allows anyone, regardless of their background or financial limitations, to expand their horizons and gain insights from experts in various disciplines. One of the most significant advantages of downloading PDF books and manuals lies in their portability. Unlike physical copies, digital books can be stored and carried on a single device, such as a tablet or smartphone, saving valuable space and weight. This convenience makes it possible for readers to have their entire library at their fingertips, whether they are commuting, traveling, or simply enjoying a lazy afternoon at home. Additionally, digital files are easily searchable, enabling readers to locate specific information within seconds. With a few keystrokes, users can search for keywords, topics, or phrases, making research and finding relevant information a breeze. This efficiency saves time and effort, streamlining the learning process and allowing individuals to focus on extracting the information they need. Furthermore, the availability of free PDF books and manuals fosters a culture of continuous learning. By removing financial barriers, more people can access educational resources and pursue lifelong learning, contributing to personal growth and professional development. This democratization of knowledge promotes intellectual curiosity and empowers individuals to become lifelong learners, promoting progress and innovation in various fields. It is worth noting that while accessing free Zf 2000 Gearbox Manual PDF books and manuals is convenient and cost-effective, it is vital to respect copyright laws and intellectual property rights. Platforms offering free downloads often operate within legal boundaries, ensuring that the materials they provide are either in the public domain or authorized for distribution. By adhering to copyright laws, users can enjoy the benefits of free access to knowledge while supporting the authors and publishers who

make these resources available. In conclusion, the availability of Zf 2000 Gearbox Manual free PDF books and manuals for download has revolutionized the way we access and consume knowledge. With just a few clicks, individuals can explore a vast collection of resources across different disciplines, all free of charge. This accessibility empowers individuals to become lifelong learners, contributing to personal growth, professional development, and the advancement of society as a whole. So why not unlock a world of knowledge today? Start exploring the vast sea of free PDF books and manuals waiting to be discovered right at your fingertips.

FAQs About Zf 2000 Gearbox Manual Books

1. Where can I buy Zf 2000 Gearbox Manual books? Bookstores: Physical bookstores like Barnes & Noble, Waterstones, and independent local stores. Online Retailers: Amazon, Book Depository, and various online bookstores offer a wide range of books in physical and digital formats.
2. What are the different book formats available? Hardcover: Sturdy and durable, usually more expensive. Paperback: Cheaper, lighter, and more portable than hardcovers. E-books: Digital books available for e-readers like Kindle or software like Apple Books, Kindle, and Google Play Books.
3. How do I choose a Zf 2000 Gearbox Manual book to read? Genres: Consider the genre you enjoy (fiction, non-fiction, mystery, sci-fi, etc.). Recommendations: Ask friends, join book clubs, or explore online reviews and recommendations. Author: If you like a particular author, you might enjoy more of their work.
4. How do I take care of Zf 2000 Gearbox Manual books? Storage: Keep them away from direct sunlight and in a dry environment. Handling: Avoid folding pages, use bookmarks, and handle them with clean hands. Cleaning: Gently dust the covers and pages occasionally.
5. Can I borrow books without buying them? Public Libraries: Local libraries offer a wide range of books for borrowing. Book Swaps: Community book exchanges or online platforms where people exchange books.
6. How can I track my reading progress or manage my book collection? Book Tracking Apps: Goodreads, LibraryThing, and Book Catalogue are popular apps for tracking your reading progress and managing book collections. Spreadsheets: You can create your own spreadsheet to track books read, ratings, and other details.
7. What are Zf 2000 Gearbox Manual audiobooks, and where can I find them? Audiobooks: Audio recordings of books, perfect for listening while commuting or multitasking. Platforms: Audible, LibriVox, and Google Play Books offer a wide selection of audiobooks.

8. How do I support authors or the book industry? Buy Books: Purchase books from authors or independent bookstores. Reviews: Leave reviews on platforms like Goodreads or Amazon. Promotion: Share your favorite books on social media or recommend them to friends.
9. Are there book clubs or reading communities I can join? Local Clubs: Check for local book clubs in libraries or community centers. Online Communities: Platforms like Goodreads have virtual book clubs and discussion groups.
10. Can I read Zf 2000 Gearbox Manual books for free? Public Domain Books: Many classic books are available for free as they're in the public domain. Free E-books: Some websites offer free e-books legally, like Project Gutenberg or Open Library.

Find Zf 2000 Gearbox Manual :

[think and grow rich 10 cd set](#)

[this day in us military history 2016 boxeddaily calendar](#)

~~thomas bus wiring diagram manual~~

thomas friends sticker scene book

three seasons jamelle e mckenzie

thoughts on pakistan by dr ambedkar

this way to the revolution a memoir

[thesiger in arabia the marsh arabs and arabian sands](#)

thomas calculus 12th edition solutions

third grade social studies pacing guide

[third wave feminism expanded second edition](#)

[third world women and the politics of feminism](#)

~~thomson service manual~~

~~thomas hematopoietic cell transplantation 5th edition~~

they came to japan an anthology of european reports on japan 1543 1640

Zf 2000 Gearbox Manual :

pdf sances giovanni felice 1600 1679 il quarto libro - Aug 23 2022

web sances giovanni felice 1600 1679 il quarto libro the labor market and employment security jun 12 2020 winter exhibition

sep 08 2022 annual report of the chief of

sances giovanni felice 1600 1679 il quarto libro - Mar 18 2022

web sances giovanni felice 1600 1679 il quarto libro delle cantate et arie venezia 1636 rev fabio anti fabio anti 2017 08 12 la versione integrale in notazione moderna

giovanni felice sances wikiwand - Mar 30 2023

web composed by giovanni felice sances 1600 1679 baroque period from cantade libro quarto venetia 1636 edited by felipe dias 5 pages this product was created by a

sances giovanni felice 1600 1679 il quarto libro delle - Apr 30 2023

web giovanni felice sances also sancies sancis sanes sanchez ca 1600 24 november 1679 was an italian singer and a baroque composer he was renowned in europe

giovanni felice sances choralwiki cpdl - Jul 02 2023

web aug 12 2017 sances giovanni felice 1600 1679 il quarto libro delle cantate et arie venezia 1636 rev fabio anti italian edition anti fabio on amazon com free

sances giovanni felice encyclopedia com - Jan 28 2023

web sances giovanni felice 1600 1679 il quarto libro delle cantate et arie venezia 1636 rev fabio anti anti fabio 9781974492084 books amazon ca

sances giovanni felice 1600 1679 il quarto libro delle - Dec 27 2022

web stabat mater sances giovanni felice first publication 1638 genre categories stabat mater religious works masses 6 more sequences for voice continuo for

stabat mater sances giovanni felice imslp - Nov 25 2022

web buy sances giovanni felice 1600 1679 il quarto libro delle cantate et arie venezia 1636 rev fabio anti by online on amazon ae at best prices fast and free shipping free

sances giovanni felice 1600 1679 il quarto libro delle - May 20 2022

web sances giovanni felice 1600 1679 il quarto libro delle cantate et arie venezia 1636 rev fabio anti anti fabio amazon es libros

sances giovanni felice 1600 1679 il quarto libro - Feb 14 2022

web sep 10 2022 giovanni felice sances also sancies sancis sanes sanchez ca 1600 24 november 1679 was an italian singer and a baroque composer he was renowned in

non sia chi mi riprenda by giovanni felice sances 1600 1679 - Feb 26 2023

web sances giovanni felicesances giovanni felice italian singer teacher and composer b rome c 1600 d vienna buried nov 12

1679 after serving several patrons he

giovanni felice sances wikipedia - Oct 05 2023

web ca 1600 24 november 1679 name in other languages Санчес Джованни Феличе Τσοβάνι Φελίτσε Σάντσες ␣␣␣␣␣␣ ␣␣␣␣
␣␣ ␣␣␣␣␣ ␣␣␣ ␣␣␣ ␣

sances giovanni felice 1600 1679 il quarto libro wrbb neu - Jun 20 2022

web sances giovanni felice 1600 1679 il quarto libro delle cantate et arie venezia 1636 rev fabio anti italiano edition anti fabio amazon com mx libros

sances giovanni felice 1600 1679 il quarto libro delle - Oct 25 2022

web may 5 2022 giovanni felice sances also sancies sancis sanes sanchez ca 1600 24 november 1679 was an italian singer and a baroque composer he was renowned in

sances giovanni felice 1600 1679 il quarto libro delle - Jun 01 2023

web abebooks com sances giovanni felice 1600 1679 il quarto libro delle cantate et arie venezia 1636 rev fabio anti italian edition 9781974492084 by anti fabio and

category sances giovanni felice imslp - Sep 04 2023

web sances giovanni felice 1600 1679 il quarto libro delle cantate et arie venezia 1636 rev fabio anti italian edition anti fabio amazon sg books

giovanni felice sances wikipedia al quds university - Sep 23 2022

web sances giovanni felice 1600 1679 il quarto libro a history of musical style jan 28 2023 exceptionally clear systematic presentation of the evolution of musical style from

sances giovanni felice 1600 1679 il quarto libro delle - Aug 03 2023

web jul 18 2021 born c 1600 died 24 november 1679 biography giovanni felice sances was an italian singer and a baroque composer he was renowned in europe during his

sances giovanni felice 1600 1679 il quarto libro delle - Apr 18 2022

web sances giovanni felice 1600 1679 il quarto libro delle cantate et arie venezia 1636 rev fabio anti fabio anti 2017 08 12 la versione integrale in notazione moderna

sances giovanni felice 1600 1679 il quarto libro download only - Jul 22 2022

web this is likewise one of the factors by obtaining the soft documents of this sances giovanni felice 1600 1679 il quarto libro by online you might not require more get older to

giovanni felice sances alchetron the free social encyclopedia - Jan 16 2022

für unternehmen kostenrechnung einfach erklärt moss - Sep 03 2022

web aktuelle textaufgaben aus der kosten und leistungsrechnung mit aussagefähigen musterlösungen teil 1 transfer pricing stufenleiterverfahren gleichungsverfahren anbauverfahren activity based costing flexible plankostenrechnung

grundlagen der kosten und leistungsrechnung springerlink - Jan 07 2023

web jan 3 2023 die kostenrechnung auch kosten und leistungsrechnung klr genannt umfasst alle geschäftsvorgänge eines unternehmens anders als die finanzbuchhaltung dient die kostenrechnung eher der unternehmensinternen kommunikation sie sorgt für

kosten und leistungsrechnung praxisbeispiel einer einf 3 - Aug 02 2022

web die kosten und leistungsrechnung ist ein instrument des rechnungswesens welches die Übersichtlichkeit der betriebsbilanz erhöhen soll sie beinhaltet alle informationen über die geschäftsvorgänge und ist fast ausschließlich an unternehmensinterne personenkreise

kosten und leistungsrechnung grundlagen beispiele - Mar 09 2023

web die kosten und leistungsrechnung oder kurz klr ordnet die innerbetrieblichen kosten den ursachen für die kosten zu dabei wird nach drei kriterien unterschieden kostenträger kostenstellen und kostenarten

begriffe der kosten und leistungsrechnung klr glossar - Apr 29 2022

web die kostenrechnung ist ein oberbegriff für die unterschiedlichsten berechnungen und analysen man unterscheidet in einem unternehmen zwischen dem externen und dem internen rechnungswesen das externe rechnungswesen ist der teil der buchhaltung

kosten und leistungsrechnung definition aufgaben - May 11 2023

web die kosten und leistungsrechnung klr gehört neben z b der investitionsrechnung zum internen rechnungswesen und ist teil des controlling alternative begriffe betriebsbuchführung betriebsbuchhaltung kosten leistungsrechnung

kosten und leistungsrechnung kostenrechnung lern online net - Jan 27 2022

kosten und leistungsrechnung klr einfach erklärt - Jun 12 2023

web die kosten und leistungsrechnung kurz klr beschäftigt sich mit den kosten und leistungen die in direktem zusammenhang mit der innerbetrieblichen leistungserstellung stehen sie bildet das gegenstück zur finanzbuchhaltung im betrieblichen

kosten und leistungsrechnung definition gabler - Jul 01 2022

web entweder man senkt die kosten und erhält die leistung oder man erhöht die leistung bei gleichen kosten beides gilt als steigerung der wirtschaftlichkeit und ist bei vielen unternehmen ein gern gesehenes ziel doch dafür muss die

kostenrechnung erst

kosten und leistungsrechnung definition erklärung - Apr 10 2023

web feb 20 2021 zusammenfassend kann die kosten und leistungsrechnung als ein abrechnungssystem bezeichnet werden dessen struktur durch die drei grundelemente der kostenartenrechnung der kostenstellenrechnung und der kostenträgerrechnung und

kostenrechnung einfache definition erklärung lexikon - Dec 26 2021

kosten und leistungsrechnung klr einfach erklärt lexoffice - Nov 05 2022

web lexikon online □kosten und leistungsrechnung betriebsergebnisrechnung i allg mit kostenrechnung deckungsgleich verwandter begriff der nicht beinhaltet eine eigenständige teilrechnung zur erfassung speicherung und auswertung von

kostenrechnung definition und Grundlagen einfach erklärt - Jul 13 2023

zum verständnis der begriffe leistungen und kosten ist es hilfreich diese von anderen geläufigen begriffen und rechengrößen des rechnungswesens see more

kosten und leistungsrechnung kostenrechnung welt - Feb 08 2023

web wenn es um die einföhrung einer kostenrechnung geht kann man im normalfall nicht auf ein allgemein gültiges universales rezeptbuch zurückgreifen jeder betrieb hat seine eigenen gesetze und vorstellungen davon was eine kostenrechnung konkret leisten

kosten und leistungsrechnung einfach erklärt - Aug 14 2023

was sind leistungen als leistungen bezeichnet man alle erhöhungen des betriebsergebnisses die im zusammenhang mit der eigentlichen für see more

die kosten und leistungsrechnung leicht erklärt - Mar 29 2022

web 2 kostenrechnung leicht gemacht kosten und leistung 2022 08 19 kompakten Überblick über alles was du für deine selbstständigkeit als yogalehrer oder yogalehrerin wissen musst von der gründung über ordnungsgemäße buchführung bis hin zu

kostenrechnung leicht gemacht kosten und leistung pdf - Nov 24 2021

kosten und leistungsrechnung praxisbeispiel einer einföhrung - Oct 04 2022

web alle formeln aus dem bereich kosten und leistungsrechnung kostenlos und direkt online ansehen wir haben uns die mühe gemacht euch hier eine kostenlose formelsammlung bereitzustellen inklusiver verständlicher erklärungen und

kostenrechnung formelsammlung alle formeln kostenlos - May 31 2022

web aug 29 2018 2 mal pro woche werden videos in den kategorien bwl vwl und grundbegriffe der wirtschaft veröffentlicht thesimpleeconomics ist teil von thesimpleclub hier werden alle 8 nachhilfe kanäle auf youtube gebündelt die meisten

die kostenrechnung leicht erklärt bilanzbuchhalter weiterbildung - Feb 25 2022

web repetitorium kosten und leistungsrechnung bilanzbuchhalter leicht gemacht back repetitorium kosten und leistungsrechnung 157 50 incl vat where applicable go to checkout prüfungsvorbereitung kostenrechnung 10 online termine á 60 min in

repetitorium kosten und leistungsrechnung bilanzbuchhalter - Oct 24 2021

kosten und leistungen kostenrechnung welt der bwl - Sep 15 2023

was sind kosten kosten bezeichnen den wert aller güter und dienstleistungen die innerhalb einer abrechnungsperiode z b innerhalb eines jahres oder eines monats für die erstellung der eigentlichen betrieblichen leistung v a die produkte oder dienstleistungen des see more

kostenrechnung definition erklärung beispiele - Dec 06 2022

web jörgen erichsen die einführung einer kostenrechnung ist im grunde wenig problematisch und kann in kleineren betrieben meist innerhalb weniger wochen umgesetzt werden dabei empfiehlt es sich schrittweise und systematisch vorzugehen und bestehende strukturen

americanenglishfile1elementaryworkbookrespuestas6a pdf - Apr 30 2022

web english file elementary student s book is suitable for cefr level a1 a2english file third edition provides a balance of grammar vocabulary pronunciation and skills to give students the right mix of language and motivation to get them talking with lively lessons and

american english file 1 workbook answer key studylib es - Jul 14 2023

web biblioteca en línea materiales de aprendizaje gratuitos american english file 1 workbook answer key american english file 1 workbook answer key american

american english file 1 elementary workbook respuestas6a - Jul 02 2022

web american english file 1 elementary workbook respuestas6a is straightforward in our digital library an online right of entry to it is set as public hence you can download it instantly

pdf american english file 1 elementary workbook respuestas6a - Mar 30 2022

web american english file 1 elementary workbook respuestas6a english vocabulary in use elementary with answers aug 28 2022 vocabulary tests to accompany the popular english vocabulary in use elementary second edition test your english vocabulary in use elementary 2nd edition can be used on its own or with the companion volume

american english file level 1 e book student book workbook multi pack - Nov 06 2022

web american english file second edition e books offer all the content from the student book workbook multi packs with extra features to support your students learning students can complete interactive activities directly on the page and receive instant feedback

american english file level 1 students book workbook - Jun 01 2022

web size 1 1 mb download drive google level 1 powerpoint presentations format mspoverpoint zip size 2 5 mb download drive google access and download class audio workbook audio and all video for the american english file second edition elt oup com student americanenglishfile

answer key american english file 1 student book answers for - Oct 05 2022

web student book answer key pdf 92 pages this file contains photocopyable activities from the teacher s book of the popular course american english file 1 they are as follows grammar activity answers grammar activities communicative activity instructions

american english file 1 elementary workbook respuestas6a - Feb 26 2022

web american english file 1 elementary workbook respuestas6a american english file 1 elementary workbook respuestas6a 2 downloaded from rjonline org on 2023 08 22 by guest designed to get students speaking with texts and topics that make learners want to speak american english file is the course that gets students talking

american english file 1 workbook resuelto pdf scribd - May 12 2023

web american english file 1 workbook resuelto free pdf ebook download american english file 1 workbook resuelto download or read online ebook american english file 1 workbook resuelto in pdf format from the best user guide database advanced 3 american english file 4 workbook answer key file 5c 1 grammar b 1 he was

american english file 1 workbook answers units 1 2 pdf - Mar 10 2023

web languagecentre ir workbook answer key american english file 1 ir grammar 1a tre page 4 2 are 3 you re 4 is 5 he s 6 she 7 she s 8 is 9 it s 10 are 11 we re 12 are 13 you re u re 14 4 they 15 they re en b e 2 they re 3 you re 4 it s 5 she s 7 she s 6 they re 7 we re 8 you re vocabulary days of the week numbers

level 1 downloads american english file oxford university press - Aug 15 2023

web american english file level 1 downloads audio student book level 1 sb file 1 zip84 mb level 1 sb file 2 zip36 mb level 1 sb files 3 4 zip92 mb level 1 sb files 5 6 zip84 mb level 1 sb file 7 zip49 mb level 1 sb file 8 zip53 mb level 1 sb files 9 10 zip93 mb level 1 sb files 11 12 zip63 mb

american english file learning resources oxford university - Jan 08 2023

web american english file access and download class audio workbook audio and all video for the american english file second

edition find resources for american english file 3rd edition at american english file online practice

american english file 1 workbook pdf 4quvn052rls0 e book - Jun 13 2023

web american english file 1 workbook pdf authors clive oxenden christina latham koenig paul seligson pdf add to wishlist share 8043 views download embed this document was uploaded by our user the uploader already confirmed that they had the permission to publish it

level 1 american english file oxford university press - Dec 07 2022

web level 1 american english file oxford university press american english file progress checks level 1 downloads

[americanenglishfile1elementaryworkbookrespuestas6a](#) - Jan 28 2022

web american english file new english file american english file level 2 workbook principles of accounting volume 1 financial accounting workbook with key 71 p medicine english file third edition pre intermediate student book uk english file 2 new english file english file english file third edition elementary student book uk

american english file 1 elementary workbook respuestas6a full - Dec 27 2021

web 2 american english file 1 elementary workbook respuestas6a 2021 09 12 press with its communicativ e syllabus authentic business material and expert tips from a leading management school plus interactive multi media business result helps students learn the communicatio n skills they need for work quickly and effectively american english

american english file 1 student book flipbuilder - Apr 11 2023

web upload your pdf on flipbuilder and create a flip pdf like american english file 1 student book american english file 1 student book unit 1 unit 2 unit 3 unit 4 unit 5 unit 6 unit 7 unit 8 unit 9 unit 10 unit 11 unit 12 communication writing listening grammar bank vocab bank search zoom in thumbnails bookmarks auto flip

american english file 1 workbook resuelto documents and e - Feb 09 2023

web american english file 1 workbook resuelto free pdf ebook download american english file 1 workbook resuelto download or read online ebook american english file 1 workbook resuelto in pdf format from the best user guide database advanced 3 american english file 4 workbook answer key file 5c 1 grammar b 1 he was

solucionarios de libros de ingles gratis elsaber21 - Aug 03 2022

web dec 1 2020 solucionario de american english file second edition american english file starter 2nd edition teacher s book and workbook answer key american english file 1 2nd edition teacher s book and workbook answer key american english file 2 2nd edition teacher s book and workbook answer key american english file 3 2nd

[english file elementary workbook 1a youtube](#) - Sep 04 2022

web feb 17 2022 this video is helpful for students who do not understand how to solve workbook exercises of english file book

